



Instruction & Operation Manual



ElectroVap® HUMIDIFIERS RTH-LC Series

ELECTROVAP® RTH-LC

Contents

1.	SAFETY INSTRUCTIONS	4
1.1	INTRODUCTION	4
1.2	IMPORTANT REMARKS	5
1.3	DECLARATION OF CONFORMITY	6
1.4	ROHS DECLARATION	6
2.	PRODUCT PRESENTATION	7
2.1	CHARACTERISTICS	7
2.2	SIZE	8
2.3	HUMIDIFIER COMPONENT PARTS	9
2.4	IMPORTANT INSTRUCTIONS	10
3	INSTALLATION	11
3.1	PROCEDURE	11
3.2	WATER SUPPLY	12
3.3	DISPERSION TUBE POSITIONING	13
3.4	STEAM OUTLET	18
3.5	CONDENSATE DRAINING WITH SIPHON	19
3.6	DRAIN HOSE CONNECTION	20
3.7	ELECTRICAL CONNECTIONS	22
3.8	ELECTRICAL WIRING	24
3.9	CONTROL SIGNAL CONNECTION	26
3.10	WIRING DIAGRAMS	32
3.11	HEATING ELEMENTS WIRING DIAGRAMS	38
3.12	WATER LEVEL DETECTOR WIRING	40
3.13	OPTION: TRANSFORMER CONNECTION	41
4.	COMMISSIONING	42
5.	SYSTEM MANAGEMENT	43
5.1	MENU INFORMATION (READ ONLY)	43
5.2	SETUP MENU	45
5.3	CONTROL SYSTEM MENU	46
5.4	CHANGE SETTINGS MENU	48
5.5	MAINTENANCE ALERTS	51
5.6	DEFAULT MESSAGE	52
6.	MAINTENANCE	58
6.1	STAINLESS STEEL TANK	58
6.2	DRAIN VALVE	59
6.3	WATER INLET VALVE	60
6.4	WATER LEVEL DETECTOR	60
7.	SPARE PARTS	61
7.1	STAINLESS TANK	61
7.2	WATER INLET VALVE	62
7.3	WATER LEVEL DETECTOR	62
7.4	DRAINING CIRCUIT	62
7.5	ELECTRICAL PART	63

ELECTROVAP® RTH-LC





1. SAFETY INSTRUCTIONS

1.1 INTRODUCTION

You recently purchased the ElectroVap® RTH-LC, and we hope you enjoy this product. Thank you for the trust you place in us. The safety instructions contained in this manual are intended for specialized, qualified, and authorized personnel.

To get the best results from the humidifier, we recommend to:

- Read carefully the assembly and installation instructions in this manual.
- Keep this manual in a safe place for future reference.
- Transmit this manual in case of sale or transfer of the device, in order to guarantee the transmission of information about it.

SAFETY WARNINGS AND SYMBOLS USED IN THE MANUAL	
	Danger! Caution. General safety instruction, whose violation could lead to malfunctions and / or bodily harm to person and / or property damage.
	Danger! High voltage. There are high voltages inside the device or one of its components, the negligence of this warning can lead to serious bodily injury or death to people and / or significant material malfunctions.
	Danger! High temperature. The ElectroVap® RTH-LC uses steam during the operation and therefore surfaces and pipe-work become very hot. Ensure that equipment not sustaining high temperatures is kept away.
	Electrostatic hazard. The components of the device may be subject to deterioration as they are very sensitive to electrostatic discharge.
	Möbius strip. Some components of the device are recyclable, the user is responsible for the removal of these. Follow the recycling recommendations adapted to the materials according to the geographical area.

- If your package is damaged or missing, please make a complaint to your carrier with a receipt acknowledgment letter within 24 hours and make a declaration to your Devatec agent.
- Pictures, graphics, and values may be subject to technical changes without notice.
- Keep this instruction manual carefully, and if you have any questions that are not answered in this manual, do not hesitate to contact us or consult your Devatec agent.

Our team will be pleased to be of assistance!

ELECTROVAP® RTH-LC

1.2 IMPORTANT REMARKS

GENERAL	<p>This manual is a translation of the original French version. It contains all the details concerning the commissioning, operation and maintenance of the device.</p> <p>Maintenance, service, repairs, as well as the study of the risks and dangers associated with these operations must be carried out by qualified, competent and authorized personnel.</p> <ul style="list-style-type: none">- Make sure that all risks or dangers are defined beforehand by an authorized person, especially for works-at-height.- We also recommend installing a security perimeter.- Make sure that the power supply is switched off before performing maintenance.- Please screw periodically all the connection terminals of the power cable.
INTENDED USE	<p>This device is manufactured by Devatec is intended solely for humidification purposes, in air treatment station or in ambience. The user undertakes to use it according to the safety instructions given in this manual.</p> <p>Improper use could result in serious hazards and damages to the user, third parties and materials.</p>
STORAGE & MAINTENANCE	<p>The device must be stored in a dry, frost-free place, protected from shocks and vibrations. Handling must be carried out by at least two people or suitable lifting equipment.</p>
WATER	<p>Steam humidifiers can be used with potable, demineralized or softened water. It is absolutely forbidden to inject a chemical into the hydraulic system. Make sure that the water supply pressure does not exceed 8 bar. Always be careful that the installation meets local standards.</p>
ELECTRICITY	<p>The user ensures that electrical installation will be carried out by an authorized technician in this field. The installer must provide the correct cable section as well as the thermal-magnetic circuit breaker protection, adapted to the regulations in place in the country of installation.</p>
WARRANTY	<p>Devatec guarantees that its devices are one (1) year warranty.</p> <p>Devatec's liability will be limited exclusively to Devatec's repair or replacement of the part or product, excluding labor, disassembly, or installation costs. Devatec may also decide to refund the purchase price of the product or part of it, at its discretion. The non-compliance of these above recommendations, additional mounting and / or transformation with components other than those provided with the device or any use other than what is explicitly stated, shall be considered as not in compliance with the prescriptions, and will invalidate the warranty.</p>
LIABILITY	<p>Devatec shall be not made liable for the consequences of incorrect installation, improper use of the devices and/or their components.</p> <p>We are committed to provide you the most complete manual, although, in the air treatment field, variations are so common that the information found in this document may be subject to changes without notice.</p>

ELECTROVAP® RTH-LC

1.3 DECLARATION OF CONFORMITY

The devices identified by serial numbers between 600 000 and 699 999, meets the requirements of the following European Directives:

2014/30/UE

2014/35/UE

DEVICE TYPE	Humidifier
MODEL NAME	RTH-LC
MANUFACTURER	Devatec 185 Boulevard des Frères Rousseau 76550 Offranville - FRANCE

We the undersigned, hereby declare that the equipment specified above conforms to the above Directive(s) and Standard(s). Valid for units with serial number starting from n° 600 001

FRAMBOT Jean-François

General Manager

05/01/2021



1.4 ROHS DECLARATION

Devatec,

Confirms that the ElectroVap® RTH-LC humidifier is manufactured in compliance with the following European regulations:

2011/65/UE

This guideline regulates, after July 1st 2006, the use of mercury, cadmium, lead (soldering processes), chrome VI as well as PBB and PBDE.

MINFRAY Jean-Marie

R&D Engineer

05/01/2021



ELECTROVAP® RTH-LC

2. PRODUCT PRESENTATION

2.1 CHARACTERISTICS

The RTH-LC humidifier is an electric humidifier, designed for air humidification in air handling unit. Like all the other humidifiers of the range, it is compatible with the Blower Pack.

Standard delivery includes:

2. Steam humidifier
3. Technical documentation
4. 3 hose clamps (2 for the steam hose and 1 for the drain hose)

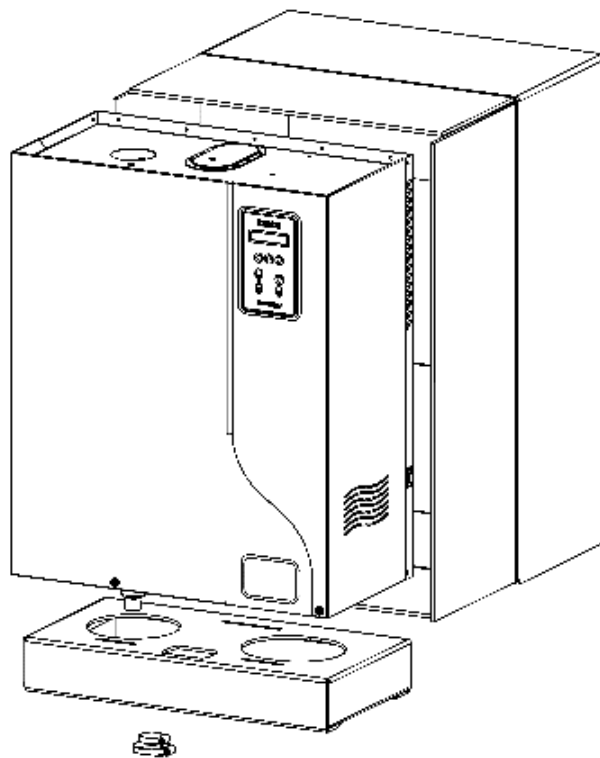

Fig. 2-1. Humidifier

ACCESSORIES (Not supplied)

- Stainless steel steam dispersion tubes
- ExpressPack®
- BlowerPack fan unit
- Steam and condensate hose
- Duct or room humidity sensor
- High Limit Humidistat
- Stainless steel braided hose in 3/4" FF (with gaskets) for connection to water network.
- Drain hose
- Remote information board
- Filling cup extension
- Transformer 3x380-690V/1x230V
- Additional cooling kit
- Outdoor protective cabinet
- Mounting bracket
- Collecting water tank
- Bluetooth kit for mobile application

ELECTROVAP® RTH-LC

2.2 SIZE

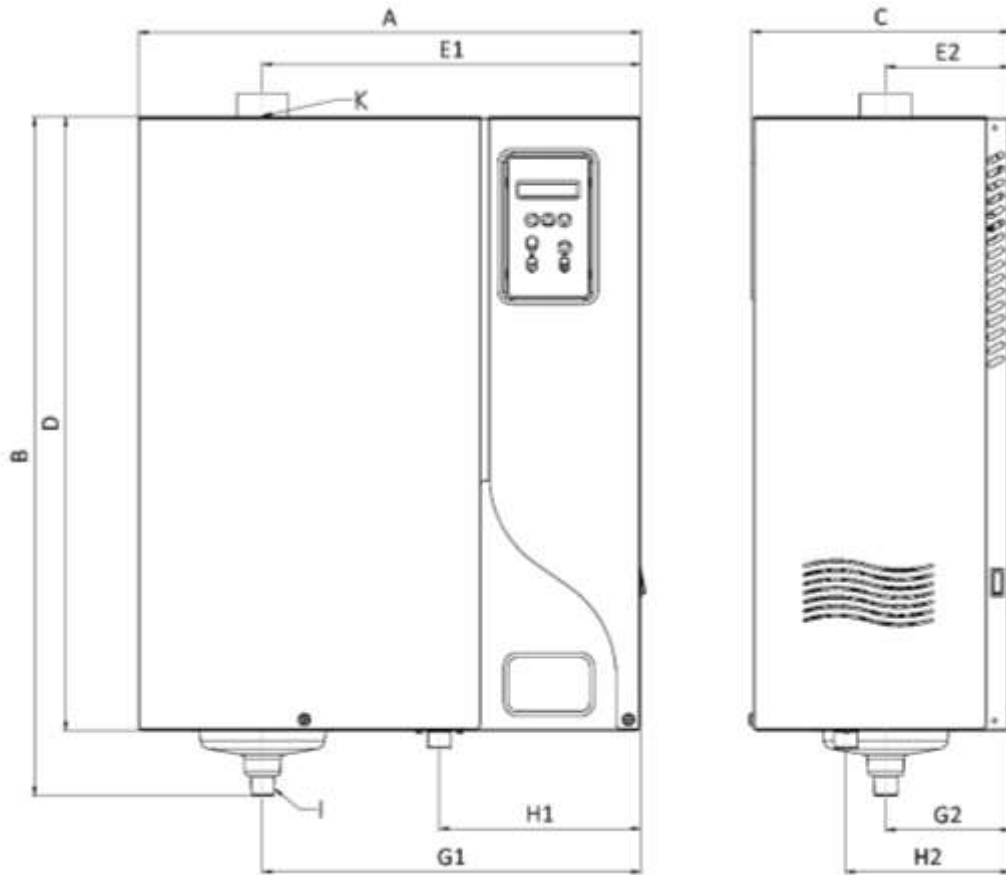

Fig. 2-2. Humidifier sizes

	RTH-LC 3-30
Number of steam outlet	1
Dimension [mm] / [in]	
A: Total width	554 / 21.81
B: Total height	750 / 29.53
C: Depth	285 / 11.22
D: Height	678 / 26.70
E1: Steam outlet position	417 / 16.42
E2: Steam outlet position	137 / 5.39
G1: Drain water position	417 / 16.42
G2: Drain water position	137 / 5.39
H1: Water inlet position	222 / 8.74
H2: Water inlet position	181 / 7.13
I: Condensate outlet diameter	∅ 25
K: Steam outlet diameter	∅ 25 or ∅ 40
Weight [kg] / [lb.]	
Weight in operation	35 / 77.16
Gross weight (packed)	25 / 55.12

ELECTROVAP® RTH-LC

2.3 HUMIDIFIER COMPONENT PARTS

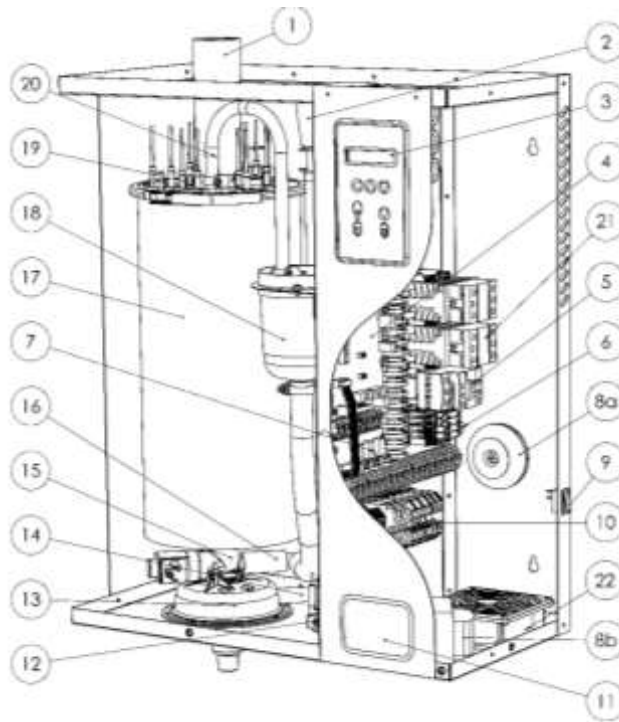

Fig. 2-3. Humidifier component parts

1	Steam hose (optional)
2	Filling cup
3	Display board
4	Main board
5	Contactur
6	Fuse holders
7	3 relay board (optional)
8a	Transformer 2x115 / 2x12V S: 50VA
8b	Transformer for UL Standards
9	ON/ OFF Switch
10	Power rail
11	Identification label
12	Inlet valve
13	Funnel
14	Overflow hose
15	Drain valve
16	Filling hose
17	Tank
18	Water level sensor
19	Heater
20	Water level hose
21	Static relay
22	Fan

ELECTROVAP® RTH-LC

2.4 IMPORTANT INSTRUCTIONS

- Ambient temperature: between 5 and 40°C
- Ambient humidity: < 80% Relative humidity
- Back side: this component heats during operation (up to 60°C). Make sure that the support of the device is not made of a heat-sensitive material.
- Wall mounting: Please be careful that the support material receiving the device (pillar, wall, etc.) can support it.
- Fixation: use a fastening system adapted to the support material.
- Make sure that the mounting distances are met.

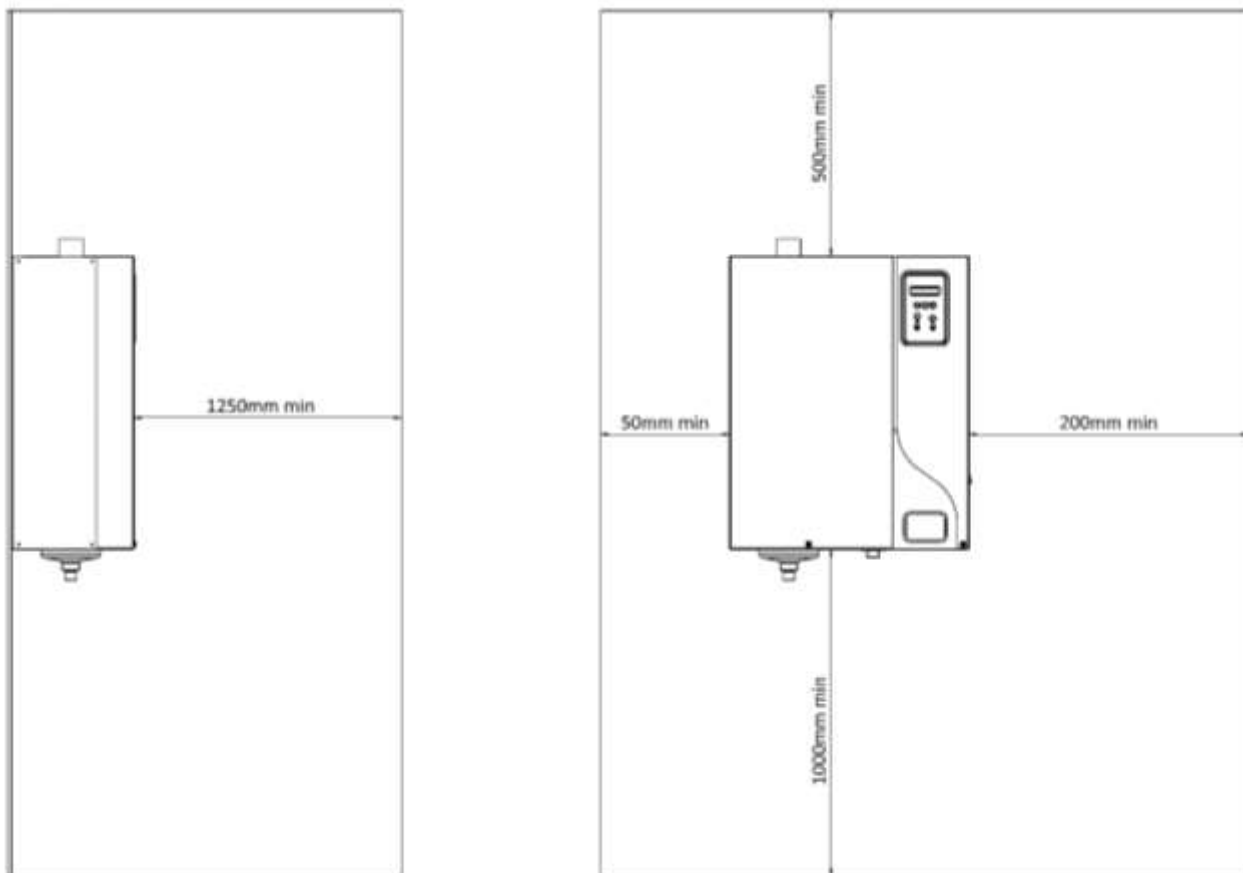

Fig.2-4. Mounting distances



Please read and follow the enclosed safety information and the warning labels inside the humidifier before installation or maintenance.

Some steps can be dangerous.

Visit our website or contact our operators for technical support.

ELECTROVAP® RTH-LC

3 INSTALLATION

3.1 PROCEDURE

- Mark and drill where indicated (holes size depends on the selected dowels and support materials).
- Put the dowels in the holes.
- Screw the top screws into the dowels (M6 recommended), let them protrude by about 10 mm/0.39in.
- Hang the device to the top screws and align it vertically and horizontally with a bubble level.
- Tighten up all screws.

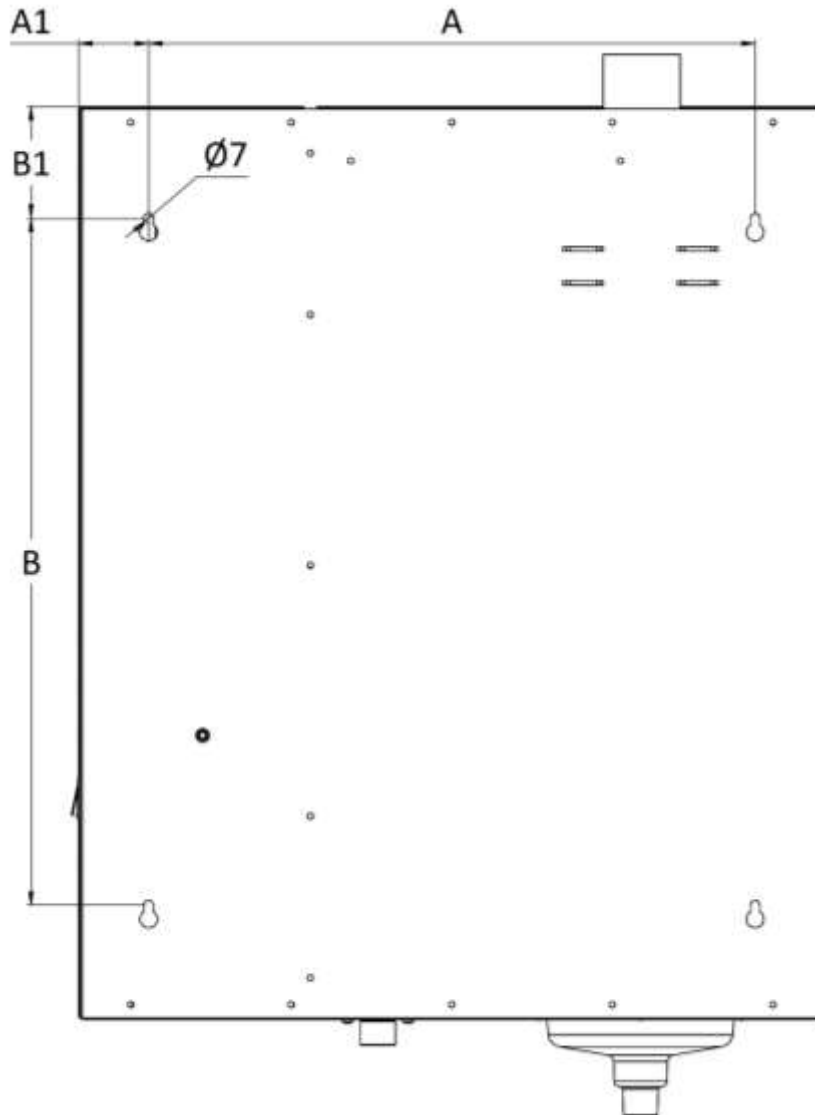

	RTH -LC [mm]/ [in]
A:	450 / 17.71
A1:	35 / 1.38
A2:	53 / 2.09
B:	510 / 20.08
B1:	81 3.19

Fig. 3-1. Installation holes

ELECTROVAP® RTH-LC

3.2 WATER SUPPLY

3.2.1 RECOMMENDATION

Our device is designed to be used with any following water type:

- ✓ drinking water (according to Directive 98/83/EEC), softened water use possible under conditions. Please contact our services.
- ✓ demineralized water, reverse osmosis water

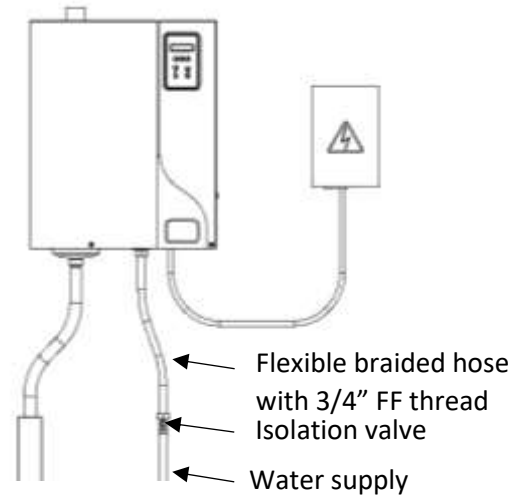

Fig. 3-2. Humidifier water supply



The demineralized water is corrosive; use appropriate piping material: stainless steel, PVC.

Softened water: Its use is not recommended, but possible. **TH 12°FH minimum.**

Water analysis is recommended to determine the level of sodium chloride.

Do not hesitate to contact our services for support.



An excess of sodium chloride may generate foam which disturbs the correct running of the humidifier. **It is essential to install a duplex softener.**
Max. chloride content: 80 mg/l

3.2.2 RECOMMENDATIONS ON CONNECTION

Network water pressure: The pressure must be stable and between 2 bar and 8 bar MAX.

Network water temperature: < 40 °C.

Please note that the water supply is connected at the lower part of the unit.

For easy maintenance, the water inlet valve is equipped with a filter strainer which should be checked periodically. It is essential to install an isolation valve near the humidifier in order to facilitate maintenance.



OVERFLOW RISKS: it is recommended to install a collecting water tank under the humidifiers to prevent overflow. This is essential if the unit is installed in false ceilings or above important rooms (example: museum room, showroom, laboratory etc.). Make sure the container is connected to the wastewater system.

ELECTROVAP® RTH-LC

3.3 DISPERSION TUBE POSITIONING

Steam dispersion tubes:

The steam from the humidifier is injected in a duct or an air handling unit via a steam dispersion tube. In order to obtain the best performance of the humidifier, select the longest pipe.

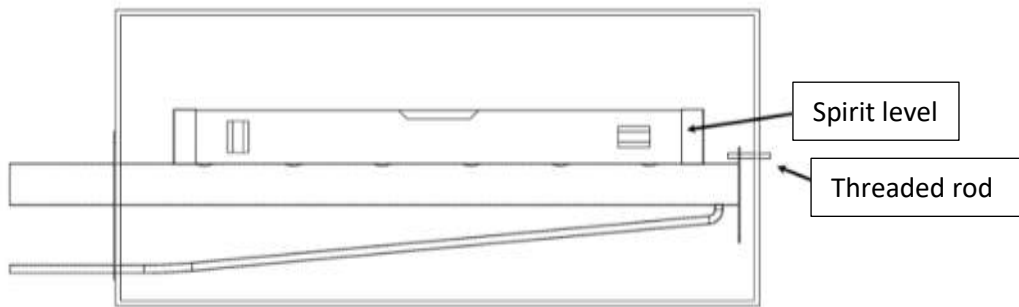

Fig. A 3-3. Steam dispersion tubes positioning

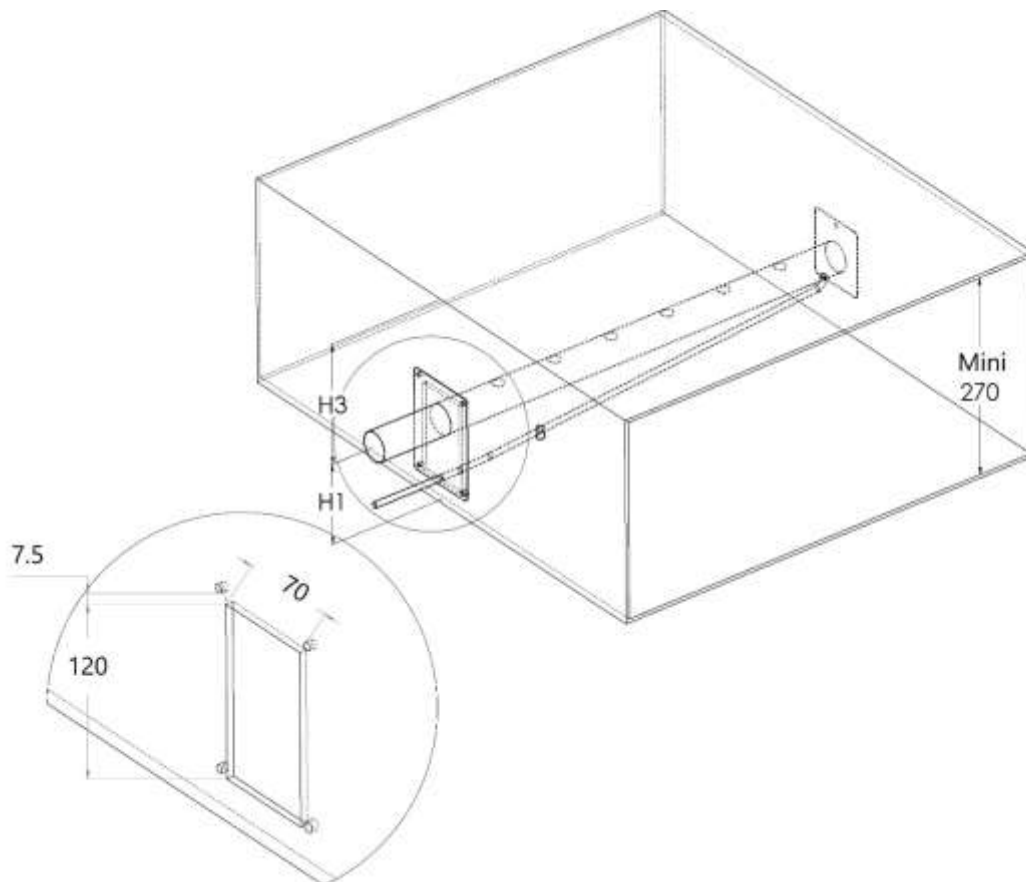

Fig. B 3-3. Hole dimension to be cut in the duct

ELECTROVAP® RTH-LC

3.3.1 Absorption distance "D"

Make sure that the absorption distance is met in order to let the air absorb the steam dispersed by the tubes. In this absorption distance, the steam is still visible in the air stream in the form of fog. If any furniture is placed in this area, condensate may occur. For this reason, it is imperative to consider this absorption distance when placing the humidifiers.

3.3.2 HOW TO CALCULATE ABSORPTION DISTANCE « D »

In order to determine the absorption distance, the attached calculation table can be used:

- RH1 = relative humidity of air before humidification in %.
- RH2 = relative humidity of air after humidification in %.
- D mini = minimum absorption distance in meters (m).

Outlet RH2 [%]	Inlet RH1 [%]							
	5	10	20	30	40	50	60	70
	Minimum absorption distance "D" [m]							
40	0,9	0,8	0,7	0,5	-	-	-	-
50	1,1	1	0,9	0,8	0,5	-	-	-
60	1,4	1,3	1,2	1	0,8	0,5	-	-
70	1,8	1,7	1,5	1,4	1,2	1	0,7	-
80	2,3	2,2	2,1	1,9	1,7	1,5	1,2	0,8
90	3,5	3,4	3,2	2,9	2,7	2,4	2,1	1,7

This calculation table is to be used for temperatures between 20°C and 25°C (68°F to 77°F) (Maximum air speed 5m/s). For calculated distances, contact your Devatec agent.

3.3.2 Minimum absorption distance

The steam dispersion pipes must be positioned after the minimum specified absorption distance. Please follow the guidelines depending on the configuration of your air handling unit.

Fig. B 3-3. Before/after a fan

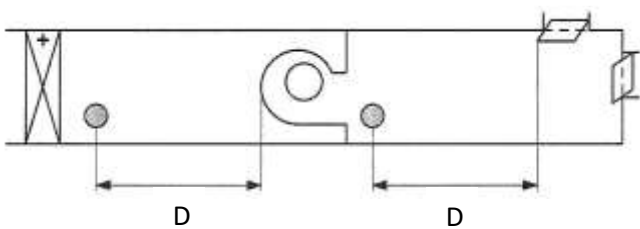
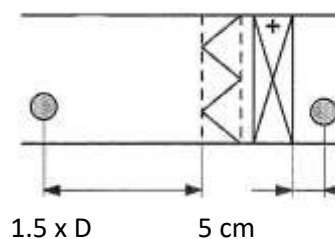

Fig. C 3-3. Before/after heating battery or filter



1.5 x D before a particle filter or absolute filter

● = Dispersion tube

ELECTROVAP® RTH-LC

3.3.3 Minimum installation distances

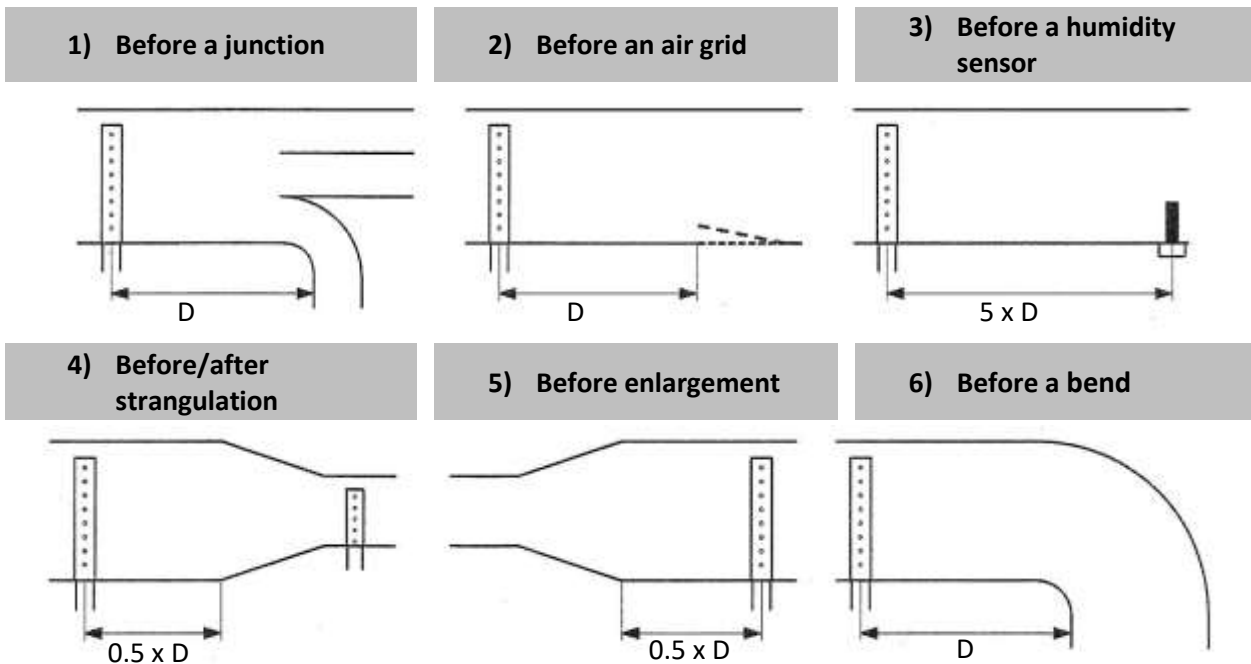

Fig. D 3-3. Installation distances

- A high limit humidistat must be installed in the duct to stop the humidifier in case the level of humidity exceeds the preset value.
- If the recommended distances cannot be met, please contact Devatec or their authorized agent for an alternative solution.
- Make sure the distances are met, if this is not possible, please contact your Devatec agent.

ELECTROVAP® RTH-LC

Make sure that spaces and distances are respected. If you have any doubts about the calculation, please contact us.

H1 = 110 mm = Minimum height between the duct floor and the axle of the steam pipe.

H2 = 140 mm minimum for a standard mounting / 110 mm minimum for a stair mounting.

H3 = 160 mm = Minimum height between the axle of the dispersion tube and the top of the duct wall.

The H3 distance can be 80 mm at the shortest, if the steam pipe is installed at a 30° angle.

In the case of a stair mounting, minimum distance between tubes = 100 mm.



Air flow direction

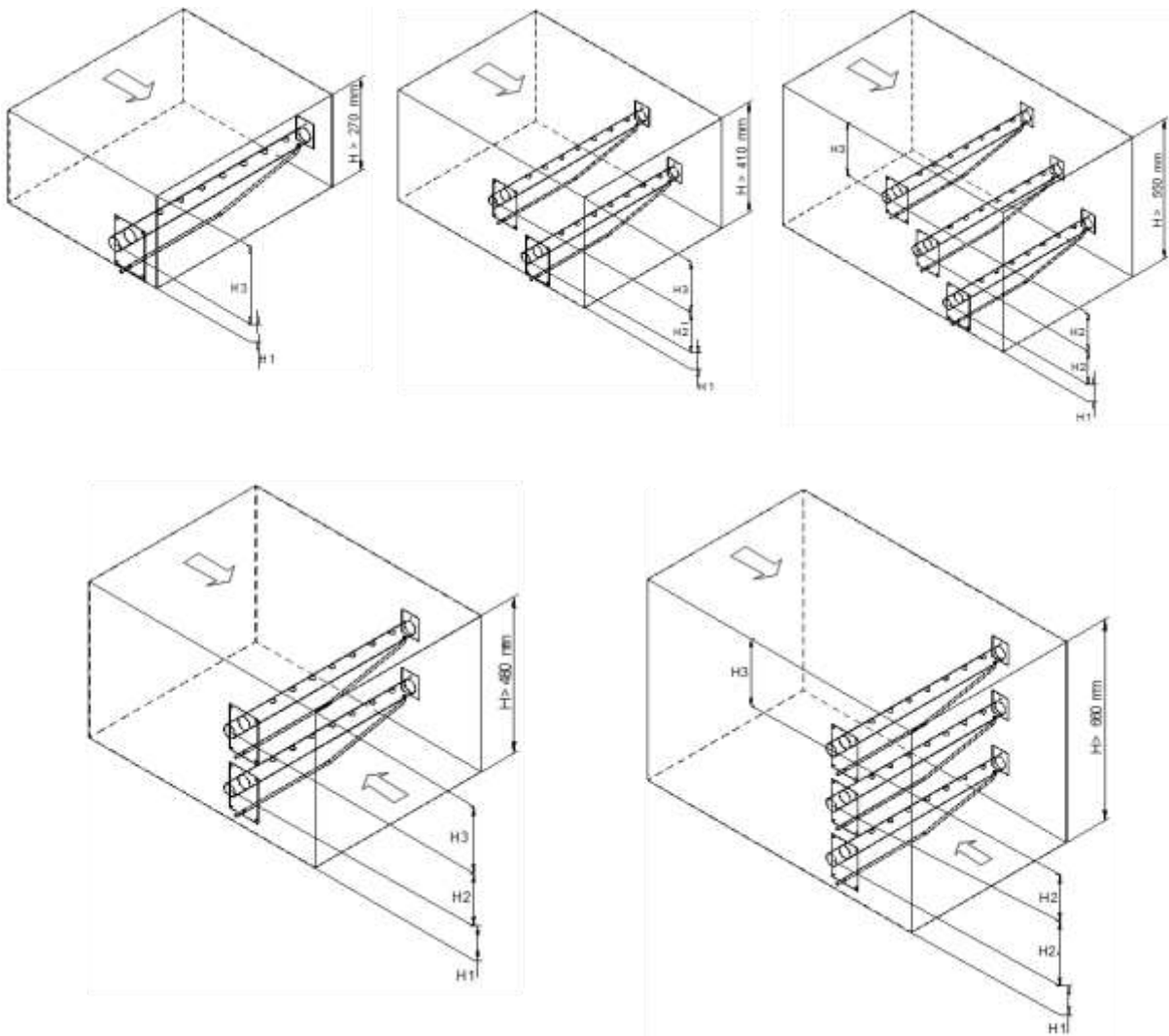

Fig. E 3-3. Minimum heights & flow directions

ELECTROVAP® RTH-LC

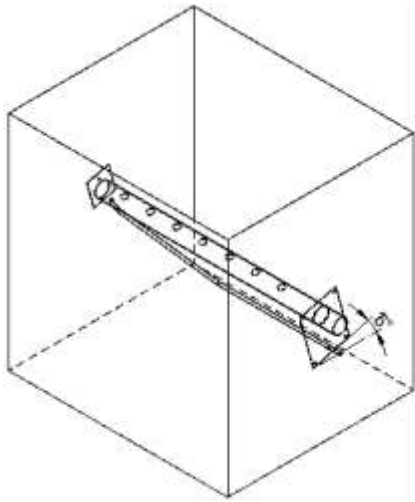

Fig. F 3-3. Vertical ducts

In vertical ducts where the air flow is upward or downward, the steam distribution pipe(s) must be tilted by 15° sideways

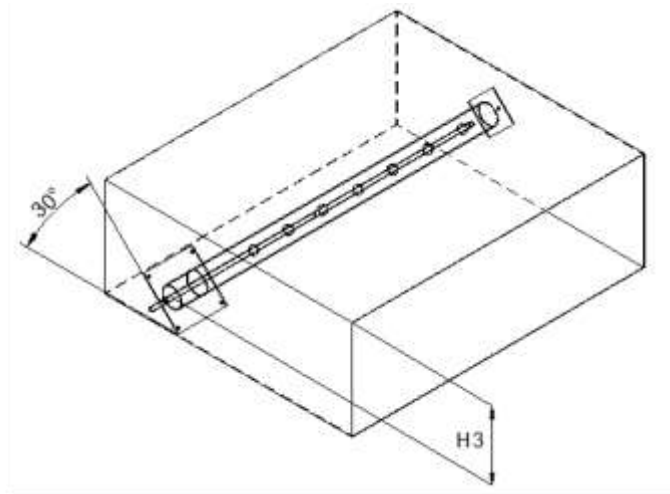

Fig. G 3-3. Ducts with limited height

In ducts with limited height, the distribution pipe(s) can be tilted by 30° to get the 80 mm minimum height

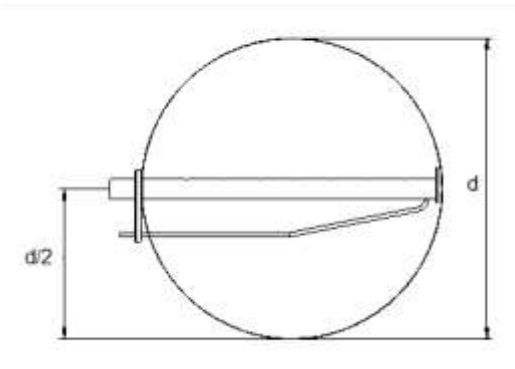

Fig. H 3-3. d = Diameter of the duct

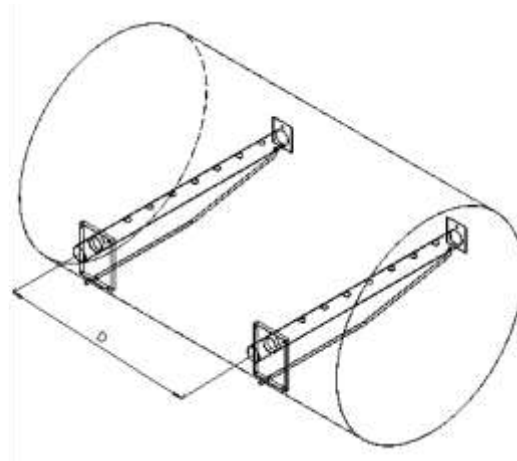

Fig. I 3-3. D = Distance between two tubes

ELECTROVAP® RTH-LC

3.4 STEAM OUTLET

1. Preferably use a flexible steam hose that is resistant to a temperature of 100°C.

NB: when new hoses are installed, a smell of burnt plastic may be smelt during the first running of the steam humidifier. This is normal and will eventually diminish.

2. Steam hose selection:

Model	RTH-LC 3 to 15	RTH-LC 20 to 30
Number of steam outlets	1	1
Steam outlet diameter	Ø 25 or Ø 40	Ø 40

3. RTH-LC humidifiers can operate with a pressure (P) higher than the atmospheric pressure in the ducts, but under the following conditions:

- If P is less than 220 mm WC or 2157 Pa.
- If P is greater than 220 mm WC (2157 Pa), options are available up to 1200 mm WC (11 768 Pa).

4. For the installation of the steam hose, depending on your environment, please respect the recommendations below and use the appropriate tangential hose clamps.

- Flexible steam hose length 3 m max.
- Stainless steel or copper pipe with a slightly larger diameter, grounded. Use a flexible steam hose cuff to connect the humidifier to the steam distribution pipe. The length of the pipe must be thermally insulated and should not exceed 6 m.



Always have a slope in the same direction (up or down); the steam hose must be free of kinks and sags to allow for gravity drainage of condensate. Make sure that the steam hose is not leaky. Failure to follow these instructions can lead to serious malfunctions.

Radius of the diameter steam pipe:

- Ø 25 - 250mm minimum
- Ø 40 - 400mm minimum

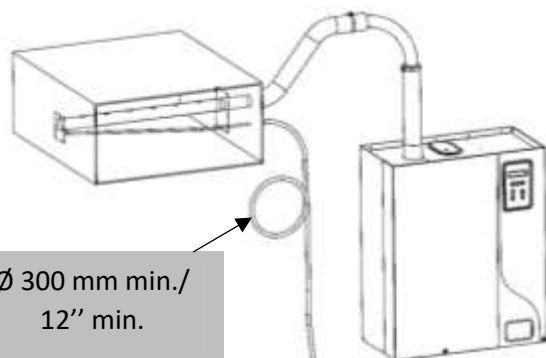

Fig. A 3-4. Standard installation

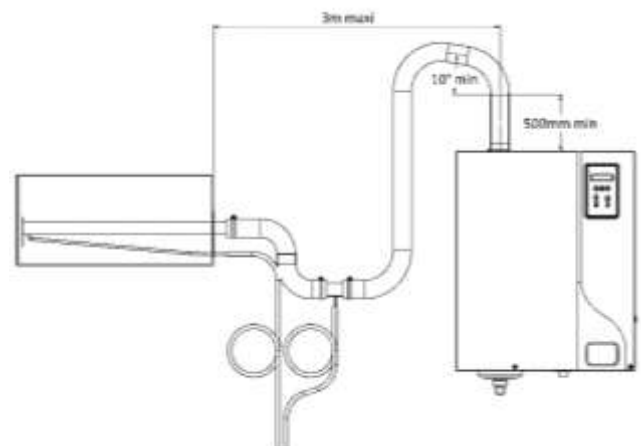

Fig. B 3-4. Additional drip leg when steam distribution below humidifier

ELECTROVAP® RTH-LC

3.5 CONDENSATE DRAINING WITH SIPHON

POSITIVE PRESSURE SIPHON

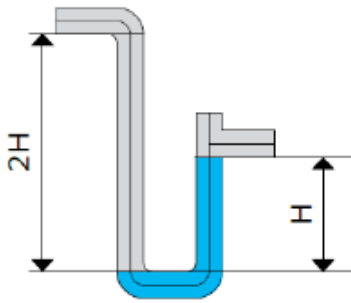

Fig. A 3-5.

NEGATIVE PRESSURE SIPHON

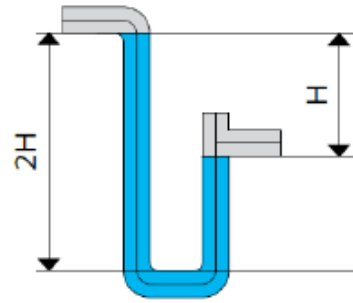

Fig. B 3-5.

The condensate hose must not be directly connected to the public sewerage network.

$$H \text{ min. (mm)} = P \text{ (Pa)} / 10$$

with P = absolute pressure of the air handling unit or the ventilation duct

ELECTROVAP® RTH-LC

3.6 DRAIN HOSE CONNECTION

The following drawing shows the drain hose connection that should be made.

Use a \varnothing 25 mm rubber drain hose with the 2 supplied hose clamps, heat-resistant (up to 100°C). Connect the hose to the draining system. Regular replacement is recommended.

If rigid piping is used, it must be a heat-resistant PVC material (up to 100 °C).

The discharge hose must be free from any obstacle.

It is recommended that each humidifier has its own drain pipe.

If possible, use a collecting water tank with a lid (see the picture below).

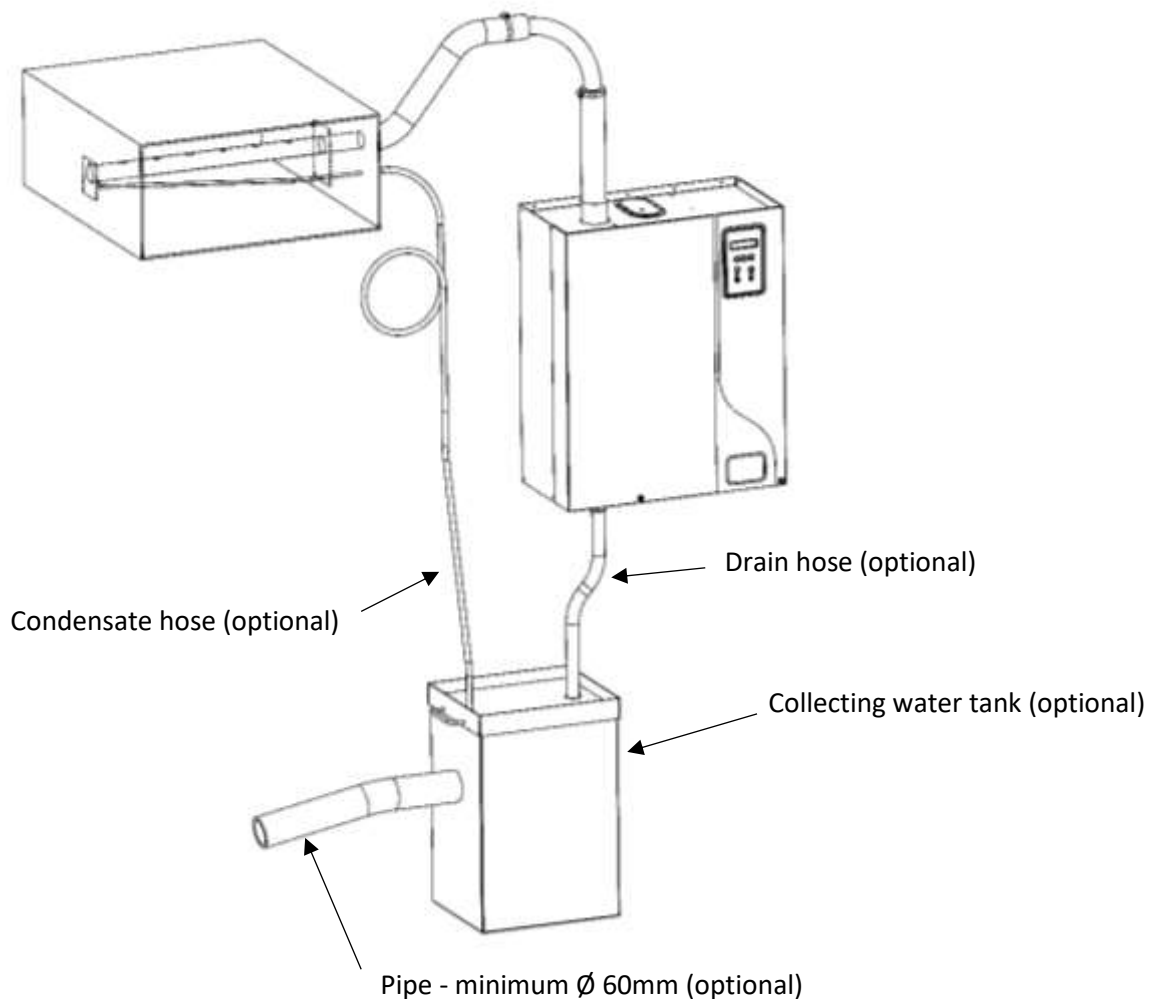

Fig. A 3-6. Example of Installation

ELECTROVAP® RTH-LC

A funnel can also be used (see picture below), but it should be offset from the underside of the unit to prevent any steam and/or condensation from getting into the cabinet.

CAUTION: keep a minimum downward slope of 10° for both the draining & overflow hoses of the humidifier and for the general drain pipe.

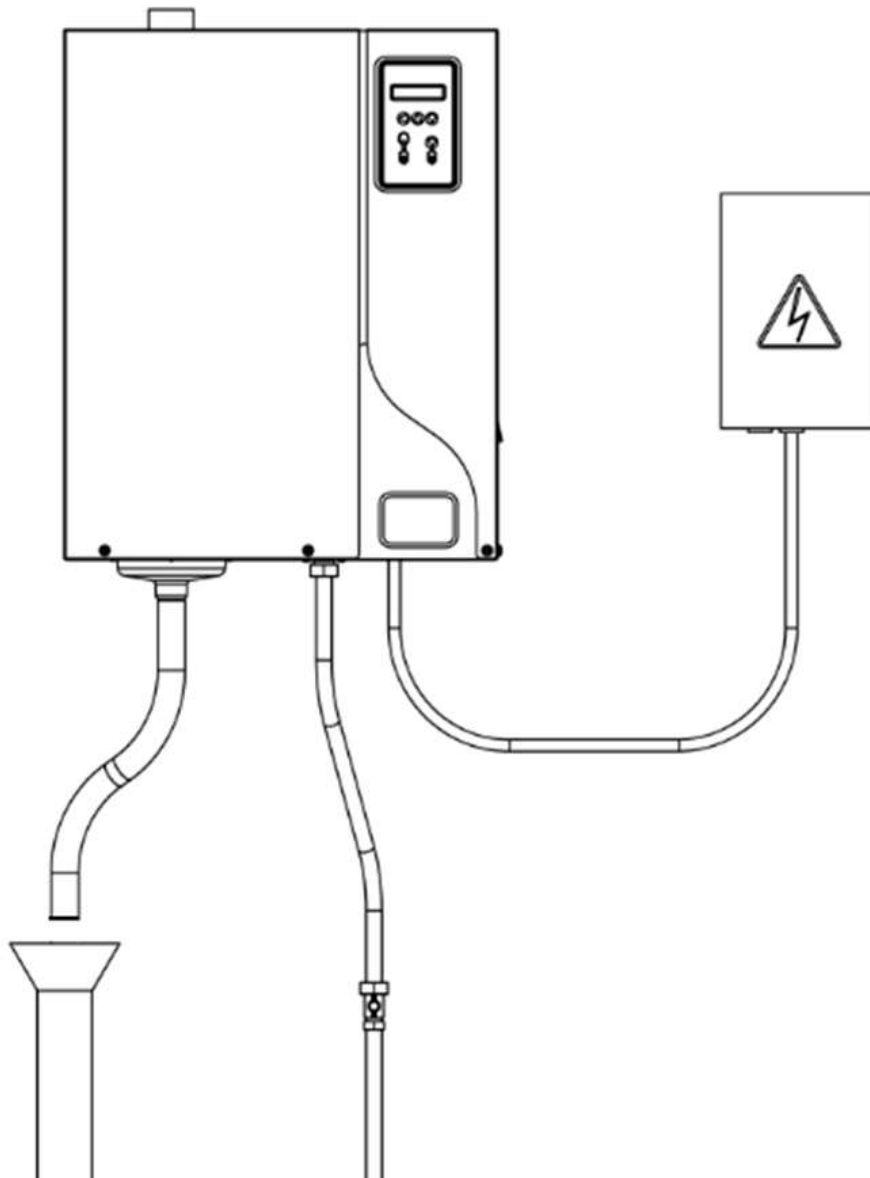

Fig. B 3-6. Example of Installation with funnel

ELECTROVAP® RTH-LC

3.7 ELECTRICAL CONNECTIONS

3.7.1 Technical data

Voltage (V)	RTH -HC	3	5	7	8	10	15	20	30
230V - 1 ph	kg/h	2.5	5.7	-	8.3	-	-	-	-
	kW (Pn)	1.9	4.3	-	6.2	-	-	-	-
	I (A)	8.3	18.7	-	27.1	-	-	-	-
208V - 3 ph	kg/h	-	-	-	6.2	-	-	-	-
	kW (Pn)	-	-	-	4.7	-	-	-	-
	I (A)	-	-	-	13.0	-	-	-	-
230V - 3 ph	kg/h	-	-	-	7.6	-	-	-	-
	kW (Pn)	-	-	-	5.7	-	-	-	-
	I (A)	-	-	-	14.4	-	-	-	-
380V - 3 ph	kg/h	-	4.7	6.9	-	10.8	15.6	21.5	26.4
	kW (Pn)	-	3.6	5.2	-	8.1	11.7	16.2	19.8
	I (A)	-	5.5	7.9	-	12.4	18	24.8	30.3
400V - 3 ph	kg/h	-	5.3	7.6	-	11.9	17.3	23.9	29.2
	kW (Pn)	-	4.0	5.7	-	9.0	13.0	17.9	22.0
	I (A)	-	5.8	8.4	-	13.0	18.9	26.1	31.9
415V - 3 ph	kg/h	-	5.7	8.2	-	12.8	18.6	25.7	31.5
	kW (Pn)	-	4.3	6.2	-	9.7	14.0	19.3	23.7
	I (A)	-	6.0	8.7	-	13.5	19.6	27.1	33.1
440V - 3 ph	kg/h	-	-	6.4	-	-	14.4	20.8	28.9
	kW (Pn)	-	-	4.8	-	-	10.9	15.6	21.7
	I (A)	-	-	6.3	-	-	14.3	20.7	28.7
460V - 3 ph	kg/h	-	-	7.0	-	-	15.8	22.7	31.6
	kW (Pn)	-	-	5.2	-	-	11.9	17.1	23.7
	I (A)	-	-	6.6	-	-	15.0	21.6	30.0
480V - 3 ph	kg/h	-	-	7.6	-	-	17.2	24.8	34.4
	kW (Pn)	-	-	5.7	-	-	12.9	18.6	25.8
	I (A)	-	-	6.9	-	-	15.6	22.6	31.3
575V - 3 ph	kg/h	-	-	7.0	-	-	15.8	22.8	31.6
	kW (np)	-	-	5.2	-	-	11.9	17.1	23.8
	I (A)	-	-	5.3	-	-	12.0	17.3	24.0
600V - 3 ph	kg/h	-	-	7.6	-	-	17.2	24.8	34.4
	kW (np)	-	-	5.7	-	-	12.9	18.6	25.9
	I (A)	-	-	5.5	-	-	12.5	18.1	25.1

ELECTROVAP® RTH-LC

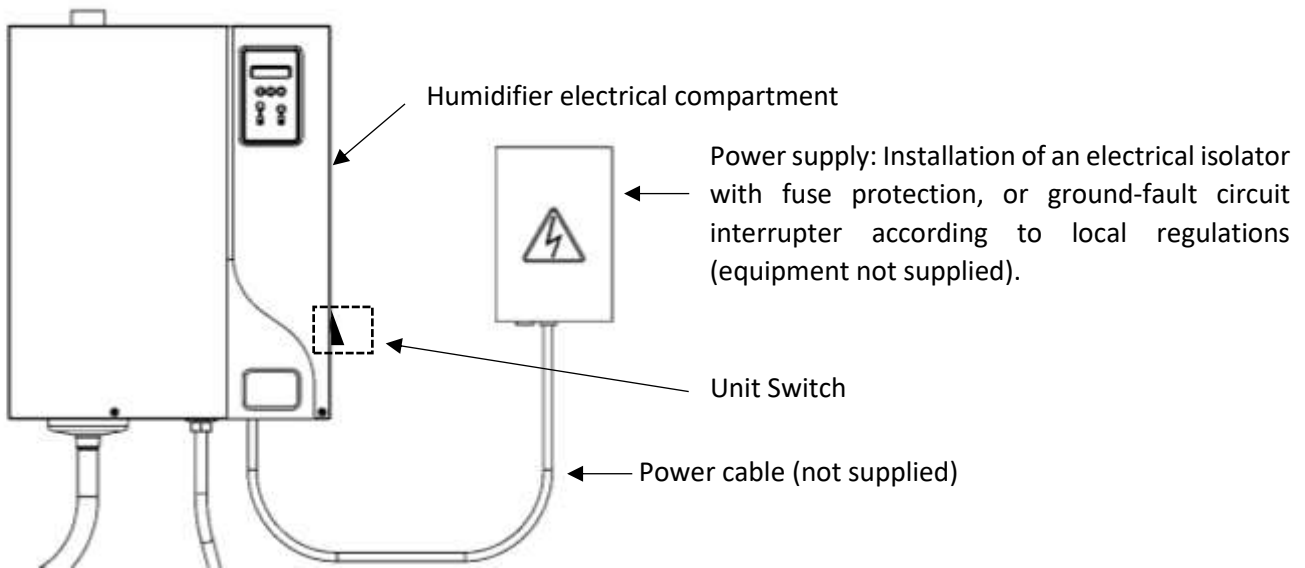





Fig. A 3-7. Electrical connections

	<p>All electrical wiring must enter the unit through a cable gland (not supplied).</p>
	<p>Unit switch: when the unit is switched off, there is still high voltage inside the unit. Electric shock may be fatal, electrical isolator must be switched off.</p>

	<p>All work on the electrical parts must be carried out by qualified and authorized personnel. In addition, before making any electrical connections, check that your installation has been determined from the values in the table on page 22. Respect local regulation concerning electrical connections.</p>
	<p>Electronic components are sensitive to electrostatic charges. When working on these components, take appropriate measures to avoid electrostatic discharges.</p>

ELECTROVAP® RTH-LC

3.8 ELECTRICAL WIRING

Up [V] = POWER VOLTAGE

Uc [V] = CONTROL VOLTAGE

Up(V) = 1x200 - 230Vac (50-60Hz)

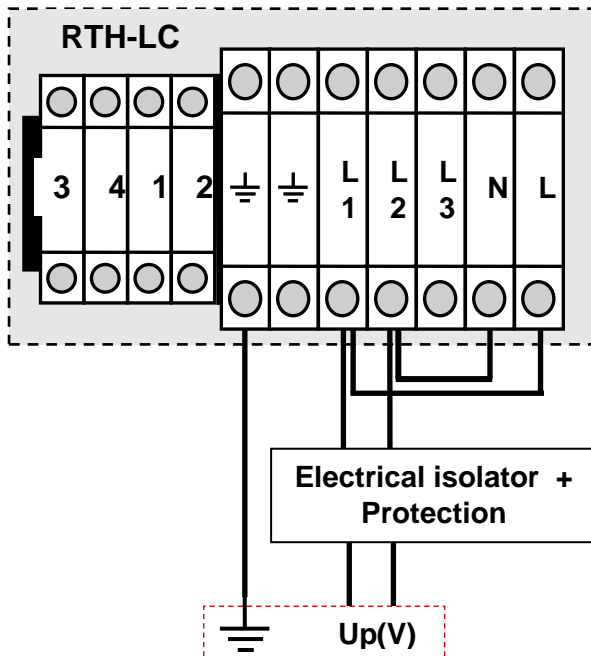

Up(V) = 3x200 - 230Vac (50-60Hz)

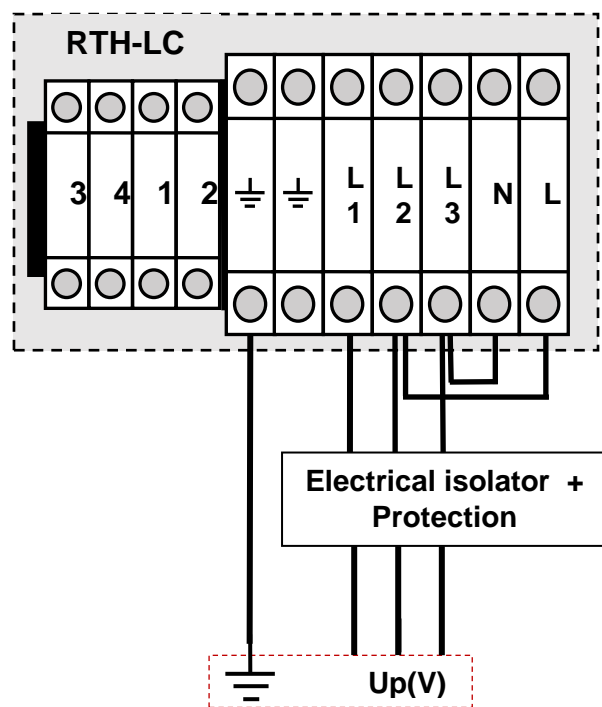

Up(V) = 3x380 - 420Vac (50-60Hz)
with neutral

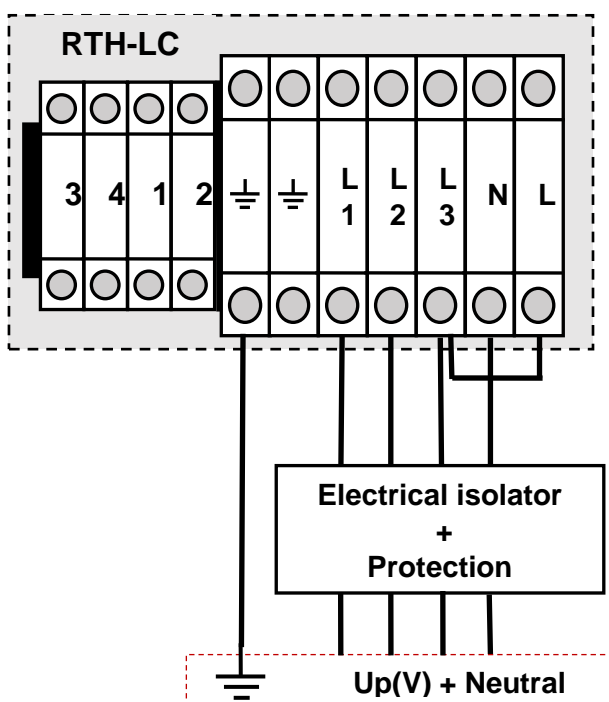

Up(V) = 3x380 - 690Vac (50-60Hz)
Uc (V) = 1x200 - 230Vac (50-60Hz)

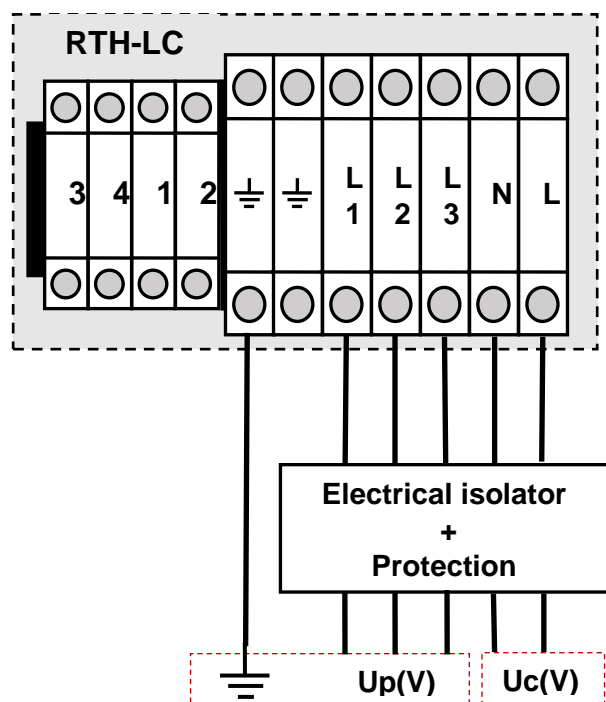

ELECTROVAP® RTH-LC

Up(V) = 3x380–690Vac (50-60Hz)

OPTION : Transformer : sec : 2x115V

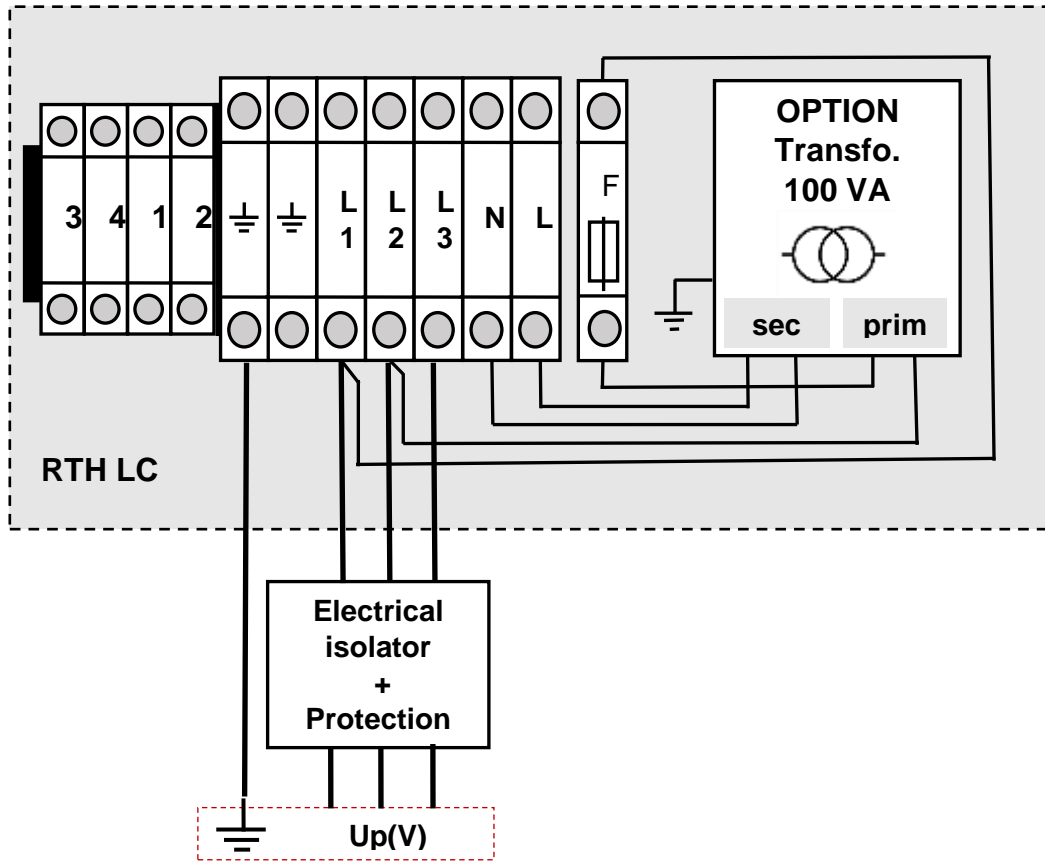

ELECTROVAP® RTH-LC

3.9 CONTROL SIGNAL CONNECTION

The wiring of the optional equipment must be made with 0.75 mm² shielded cable. This control signal wire should not be routed with a power cable.

ON/OFF CONTROL

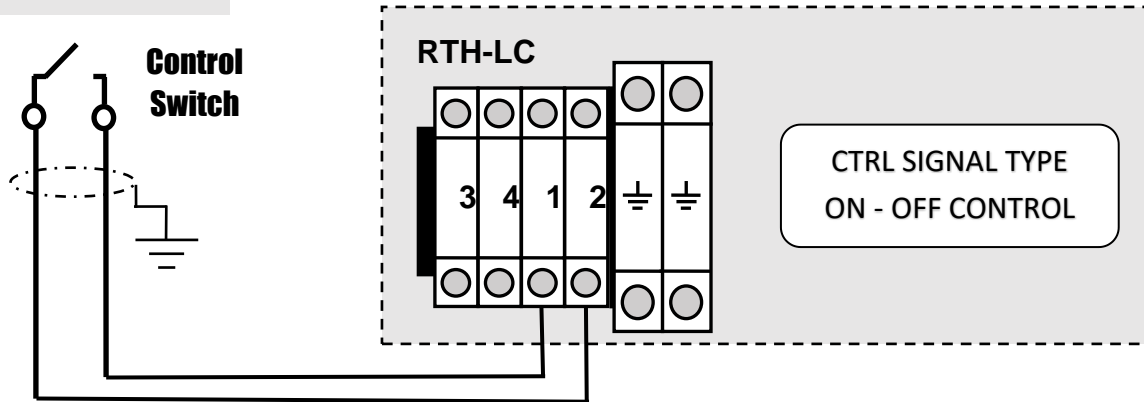

PROPORTIONAL CONTROL

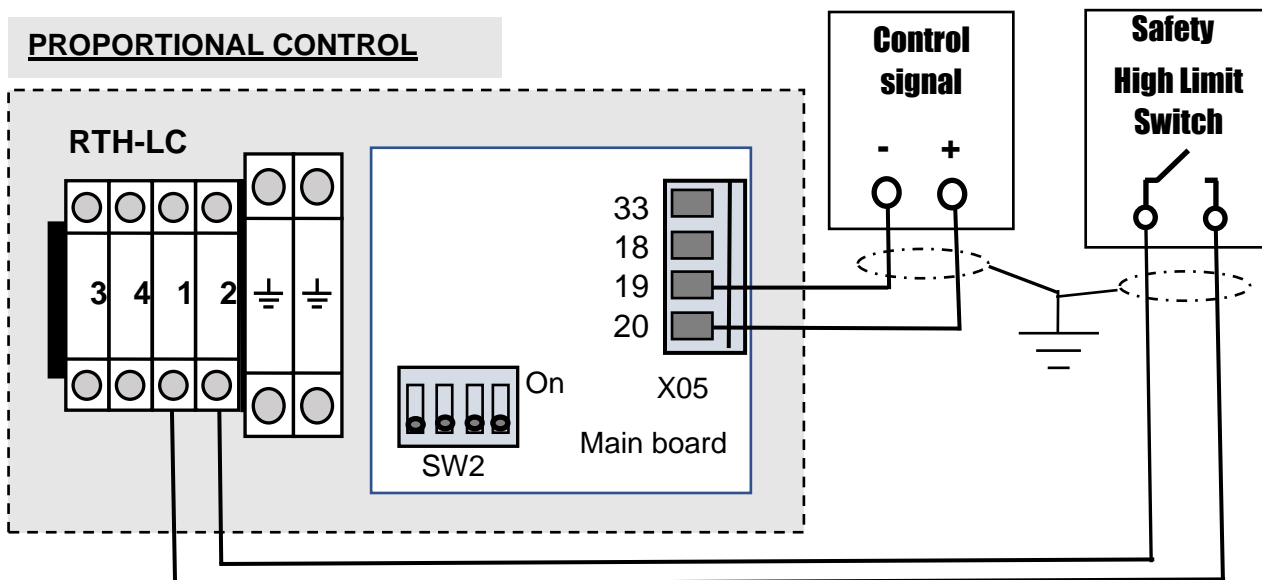

SW2 Dip switch setting to do on main board

Control signal type setting in humidifier menu

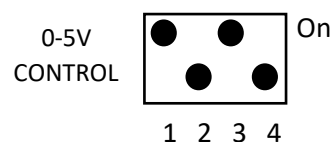
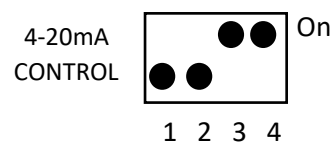
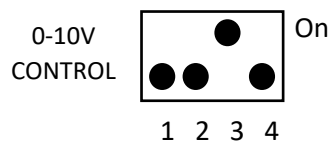

CTRL SIGNAL TYPE

0-10V CONTROL

4-20mA CONTROL

0 - 5V CONTROL

ELECTROVAP® RTH-LC

HUMIDITY SENSOR CONTROL

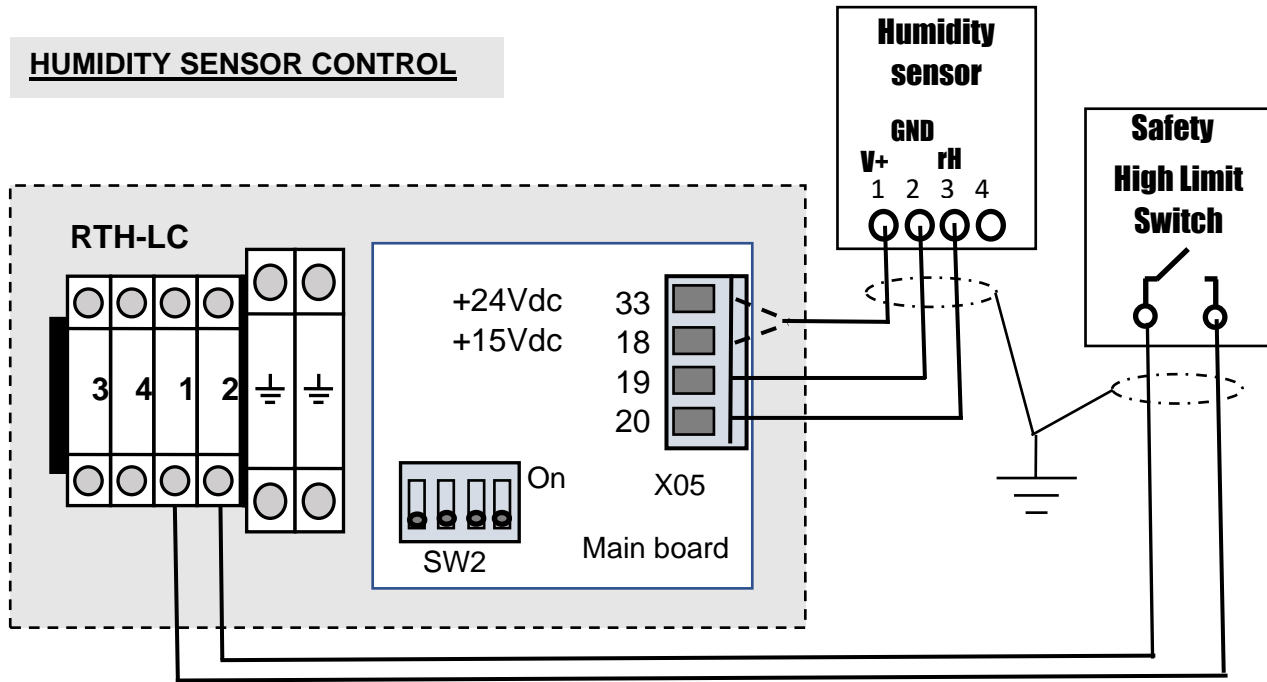

SW2 Dip switch setting to do on main board

Control signal type setting in humidifier menu

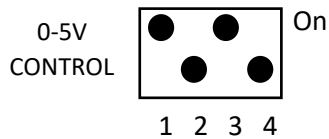
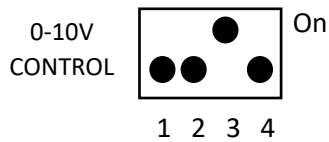

CTRL SIGNAL TYPE

0 - 10V SENSOR

0 - 5V SENSOR

WITH DIGITAL CONTROL

Control signal type setting in humidifier menu

CTRL SIGNAL TYPE
DIGITAL CONTROL

ELECTROVAP® RTH-LC

3.9.1 Remote information board

The contact can be changed to NO or NC by wiring according to the following diagrams (e.g. wiring on 30 & 31 = NO contact).

Fig. A 3-9.

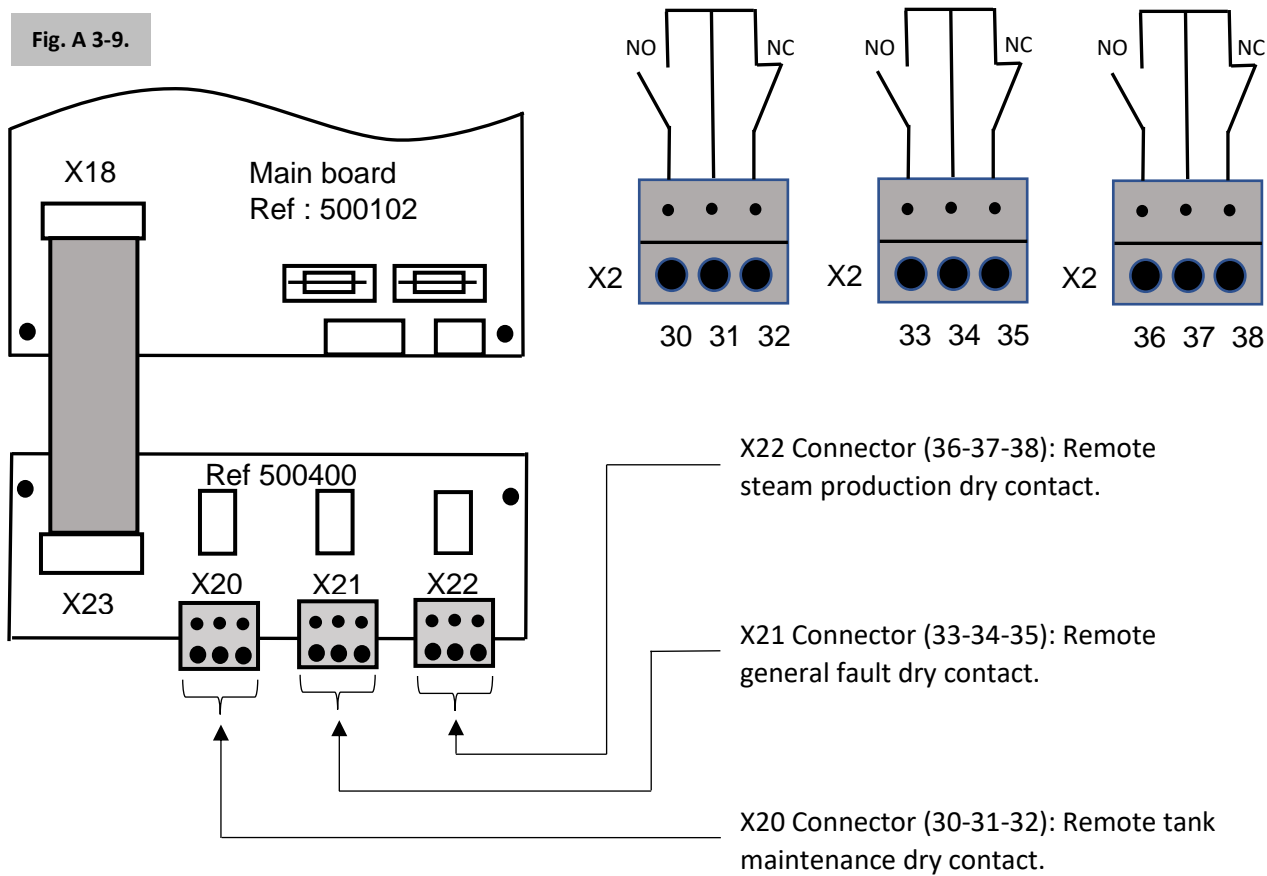

3.9.2 RS485 – Hardware connection

RS485 connection must be plugged on the J2 connector:

- Terminal 1: Data -
- Terminal 2: Data +
- Terminal 3: GND

The SW1 switch is used to turn line resistance on or off. Depending on your needs, these resistances can be activated or deactivated (see diagram).

Fig. B 3-9.

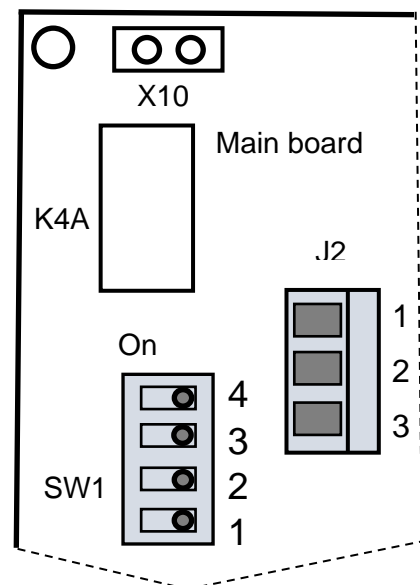
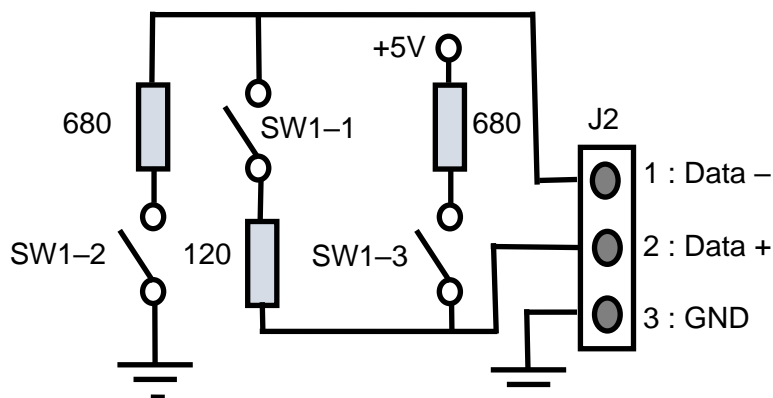

ELECTROVAP® RTH-LC

3.9.3 MODBUS RTU and BACNET MSTP communication parameters

	Modbus RTU	Bacnet MSTP
Speed of communication	2400 / 4800 / 7200 / 9600 (default) / 14400 / 19200 / 28800 / 38400 / 57600 / 115200 / 230400	
Packet size	8 bits	
Parity Bit	Not	
Stop bit	2	1
Timeout response	5000ms (5sec)	
Time between requests (After a response received)	Min. 100ms	Standard

3.9.4 Communication protocol for RS485 interface - MODBUS and BACNET

Modbus Register Address	Bacnet Object Class / instance # / ID (hex)			Description	Value
	Class	Instance #	ID (hex)		
10001	BI	0	00C00000	Fill valve	1 = filling -- 0 = no filling
10002	BI	1	00C00001	Drain valve	1 = draining -- 0 = no draining
10003	BI	2	00C00002	Contactora 1	1 is ON -- 0 is OFF
10004	BI	3	00C00003	Contactora 2	1 is ON -- 0 is OFF
10005	BI	4	00C00004	Blower pack	1 is on -- 0 is off
10006	BI	5	00C00005	Service relay	1 is ON -- 0 is OFF
10007	BI	6	00C00006	Alarm relay	1 is ON -- 0 is OFF
10008	BI	7	00C00007	Onoff Relay	1 is ON -- 0 is OFF
10009	BI	8	00C00008	High limite sw	1: detected -- 0: not detected
10010	BI	9	00C00009	Alarm A1 state	1 is ON -- 0 is OFF
10011	BI	10	00C0000A	Alarm A2 state	1 is ON -- 0 is OFF
10012	BI	11	00C0000B	Alarm A3 state	1 is ON -- 0 is OFF
10013	BI	12	00C0000C	Alarm A4 state	1 is ON -- 0 is OFF
10014	BI	13	00C0000D	Alarm A5 state	1 is ON -- 0 is OFF
10015	BI	14	00C0000E	Alarm A6 state	1 is ON -- 0 is OFF
10016	BI	15	00C0000F	Alarm A7 state	1 is ON -- 0 is OFF
10017	BI	16	00C00010	Alarm A8 state	1 is ON -- 0 is OFF
10018	BI	17	00C00011	Alarm A9 state	1 is ON -- 0 is OFF
10019	BI	18	00C00012	Alarm A10 state	1 is ON -- 0 is OFF
10020	BI	19	00C00013	Rh sensor error	1 is ON -- 0 is OFF

ELECTROVAP® RTH-LC

1	BO	0	01000000	On/Off BMS command	1 = ON : Start requested / 0 = Off: Stop Unit
2	BV	1	01400001	EOS drain statue	1 = on / 0 = off
30001	AI	0	00000000	Type unit	4 : rth 5 : rth-lc 6 : ers 7 : ers lc
30002	AI	1	00000001	Reg version	1
30003	AI	2	00000002	Demand	(%)
30004	AI	3	00000003	Steam output	10 x (Kg/hr)
30005	AI	4	00000004	Run status	1 : Idle 2 : Warm up cycle 3 : Steam production 4 : Manual Drain 5 : Ready for service 6 : Need for service operation 7 : Default 8 : Aquasta operating
30006	AI	5	00000005	Estimated time to service	(hours)
30007	AI	6	00000006	Production since last service (MSB)	(Kg)
30008	AI	7	00000007	Production since last service (LSB)	(Kg)
30009	AI	8	00000008	Total production (MSB)	(Kg)
30010	AI	9	00000009	Total production (LSB)	(Kg)
30011	AI	10	0000000A	Total run time (MSB)	(Hours)
30012	AI	11	0000000B	Total run time (LSB)	(Hours)
30013	AI	12	0000000C	Remaining idle time to EOS drain	(Hours)
30014	AI	13	0000000D	Control signal value	10 x V or 10 x ma or %
30015	AI	14	0000000E	Temperature tank 1	(°C)
30016	AI	15	0000000F	Temperature tank 2	(°C)
30017	AI	16	00000010	Alarm A2 counter	Counter for A2 default
30018	AI	17	00000011	Alarm A3 counter	Counter for A3 default
30019	AI	18	00000012	Alarm A6 counter	Counter for A6 default
30020	AI	19	00000013	Alarm A7 counter	Counter for A7 default
30021	AI	20	00000014	Alarm A8 counter	Counter for A8 default
30022	AI	21	00000015	Partial drain timer	10 x (s)
30023	AI	22	00000016	PWM main supply	Trigger value
30024	AI	23	00000017	PWM counter	Counter
30026	AI	25	00000019	Max production capability	
30027	AI	26	0000001A	Number of tank	1 or 2
30028	AI	27	0000001B	Unit type ID	Unit code name
30029	AI	28	0000001C	Unit voltage type	Voltage type code

ELECTROVAP® RTH-LC

30030	AI	29	0000001D	Water level status	Level detected from 0 to 3
30031	AI	30	0000001E	Power consumed	(kw)
30032	AI	31	0000001F	Max power rating	(kw)
40004	A0	3	00000003	Digital Rh value or digital demand	(%) mini = 1 and maxi = 100
40005	AV	4	00800004	Rh set point	(%) mini = 1 and maxi = 100
40006	AV	5	00800005	EOS drain timer	(Hour) mini = 1 and maxi = 120
40007	AV	6	00800006	Service counter	(kg / 100) from 1 to 65000
40008	AV	7	00800007	Aquastat status	1 : enable -- 2 : disable
40009	AV	8	00800008	Aquastat setpoint	Mini 10 max 80 (°C)
40010	AV	9	00800009	Control signal type	20 : onoff 21: digital ctrl 22 : digital sensor 23 : 0-10V ctrl 24 : 1-5V ctrl 25 : 4-20ma ctrl 26 : 0-10V sensor 27 : 0-5V sensor
40012	AV	11	0080000B	Control signal adjustment	(-128 %) mini 123, max 133
40014	AV	13	0080000D	Temperature 1 adjustment	(-128 %) mini 123, max 135
40015	AV	14	0080000E	Temperature 2 adjustment	(-128 %) mini 123, max 136
40016	AV	15	0080000F	Proportional factor of PID	Typ. : 20 mini 0 maxi 50
40017	AV	16	00800010	Integral factor PID	Mini 0 maxi 50
40018	AV	17	00800011	Derivative factor PID	Mini 0 maxi 50

ELECTROVAP® RTH-LC

3.10 WIRING DIAGRAMS

Up[V] - 1x200-240V 50-60Hz

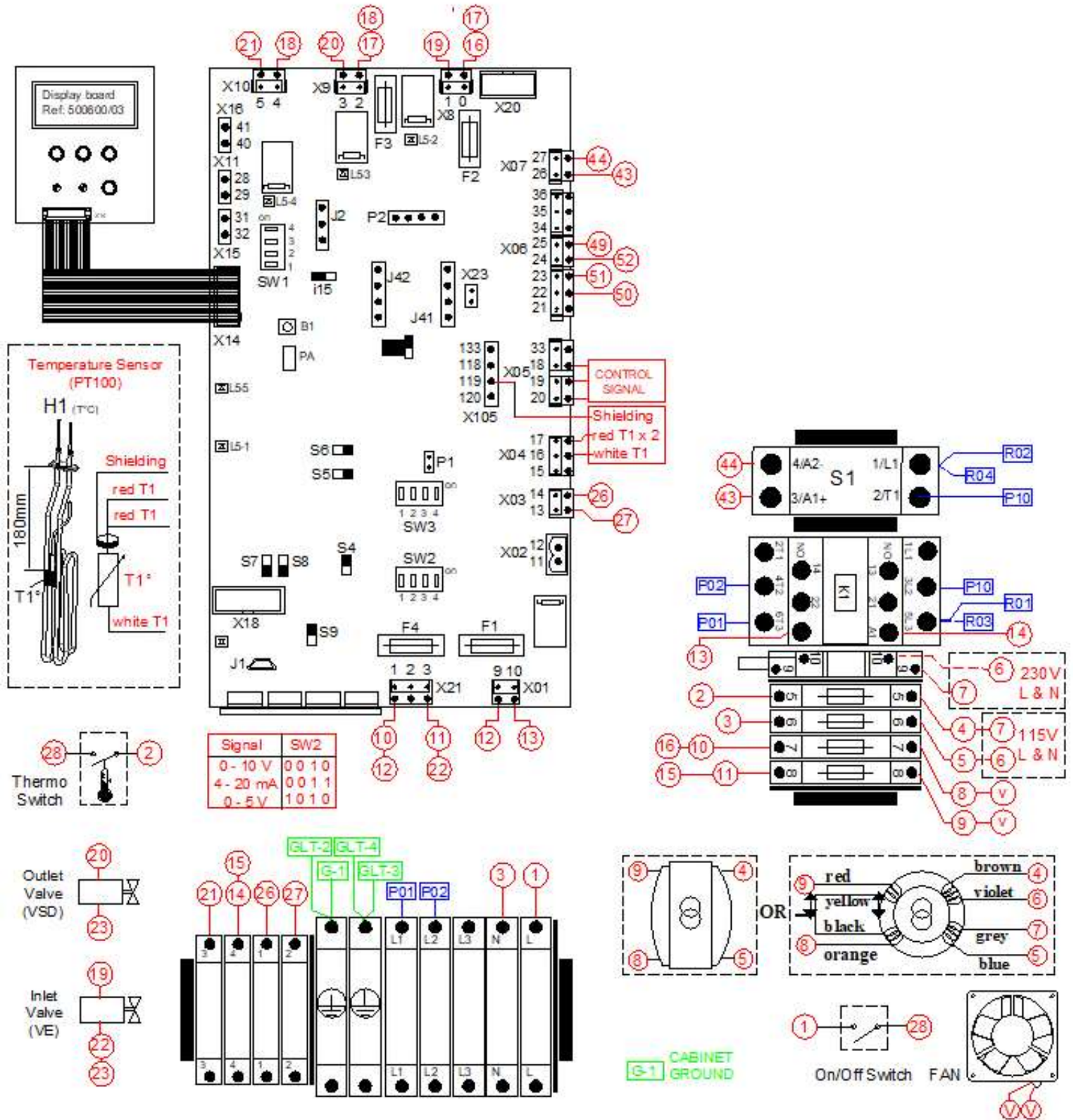

ELECTROVAP® RTH-LC

RTH-LC 8-18, Up[V] - 3x200-240V 50-60Hz

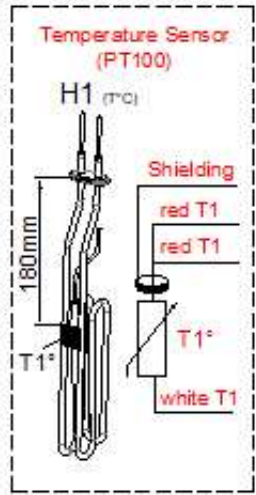
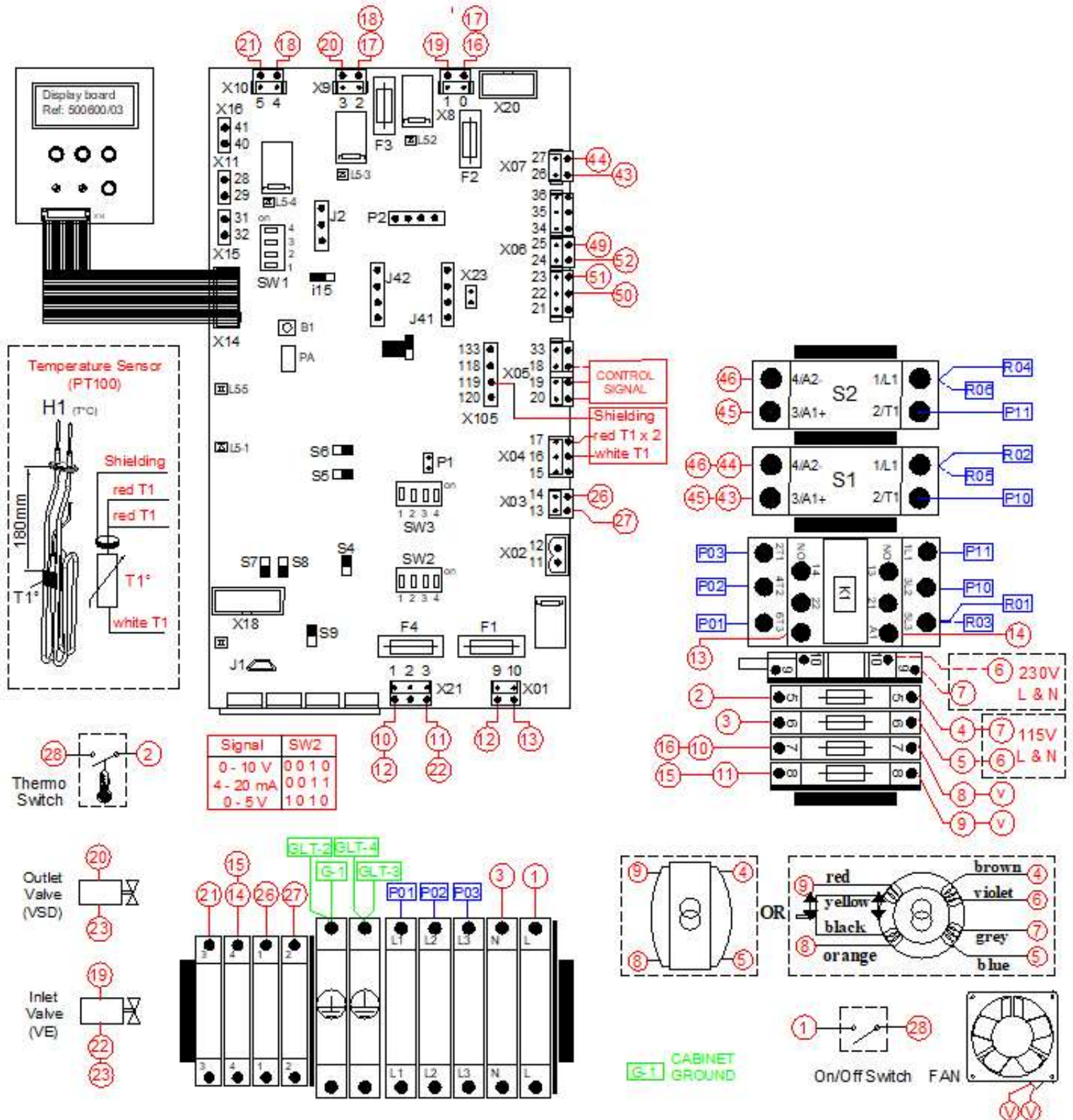

Signal	SW2
0 - 10 V	0 0 1 0
4 - 20 mA	0 0 1 1
0 - 5 V	1 0 1 0

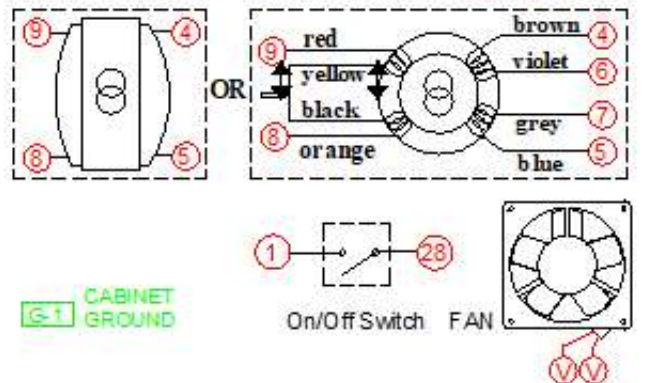
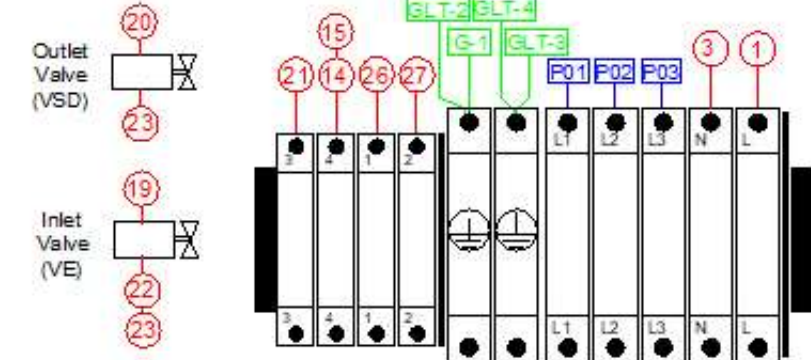
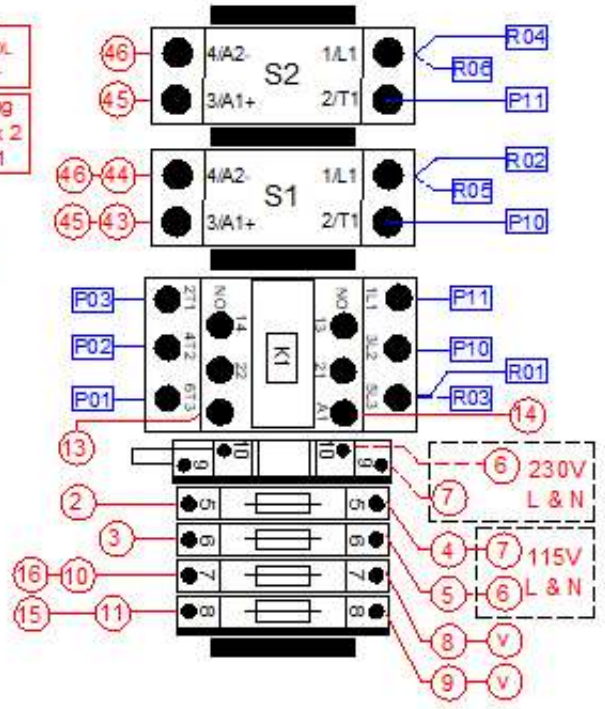

ELECTROVAP® RTH-LC

RTH-LC 5-30, Up[V] - 3x380-690V50-60Hz

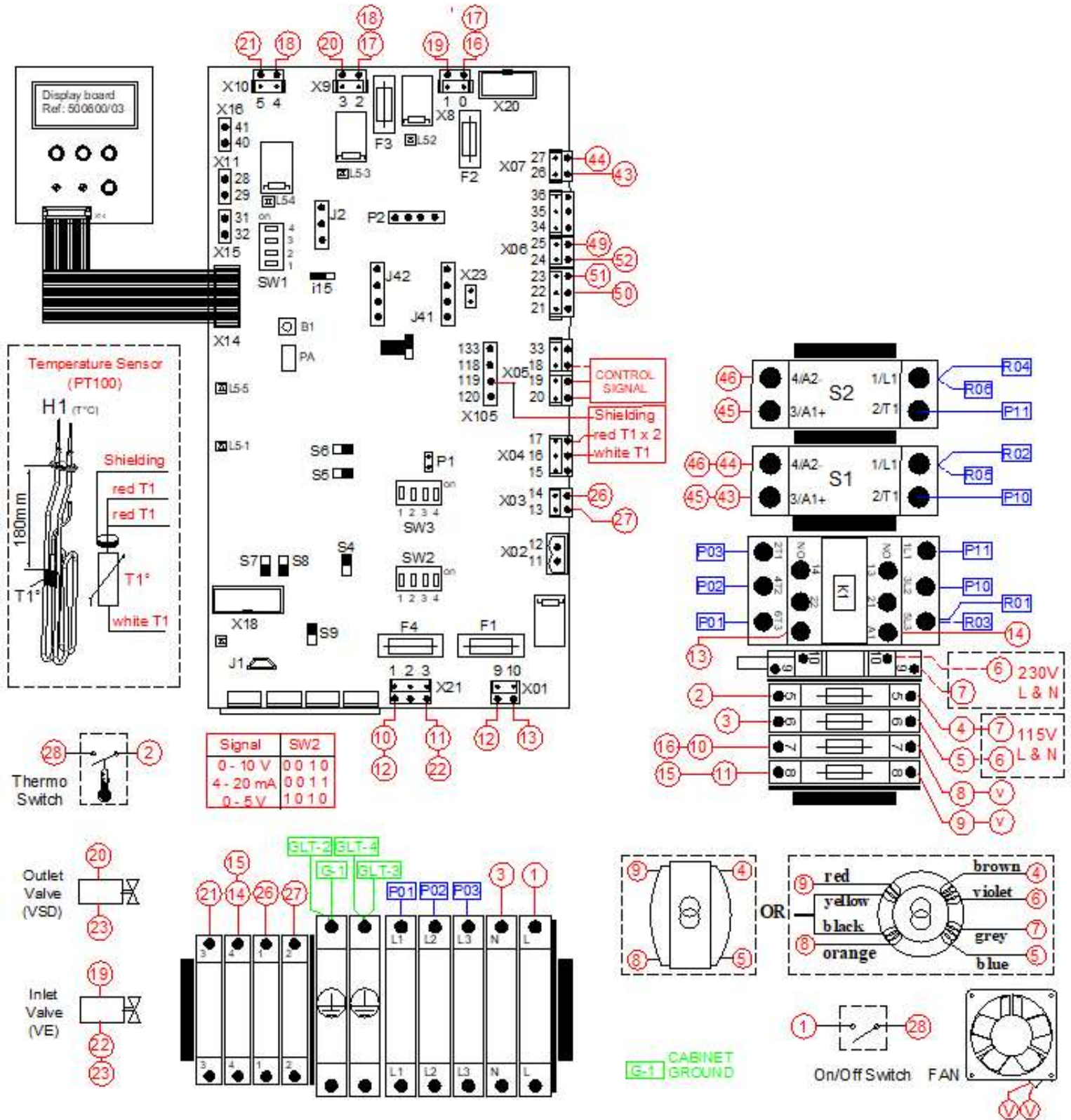

ELECTROVAP® RTH-LC

ON/OFF Range: Up[V] - 1x200-240V 50-60Hz (UL standard device not concerned)

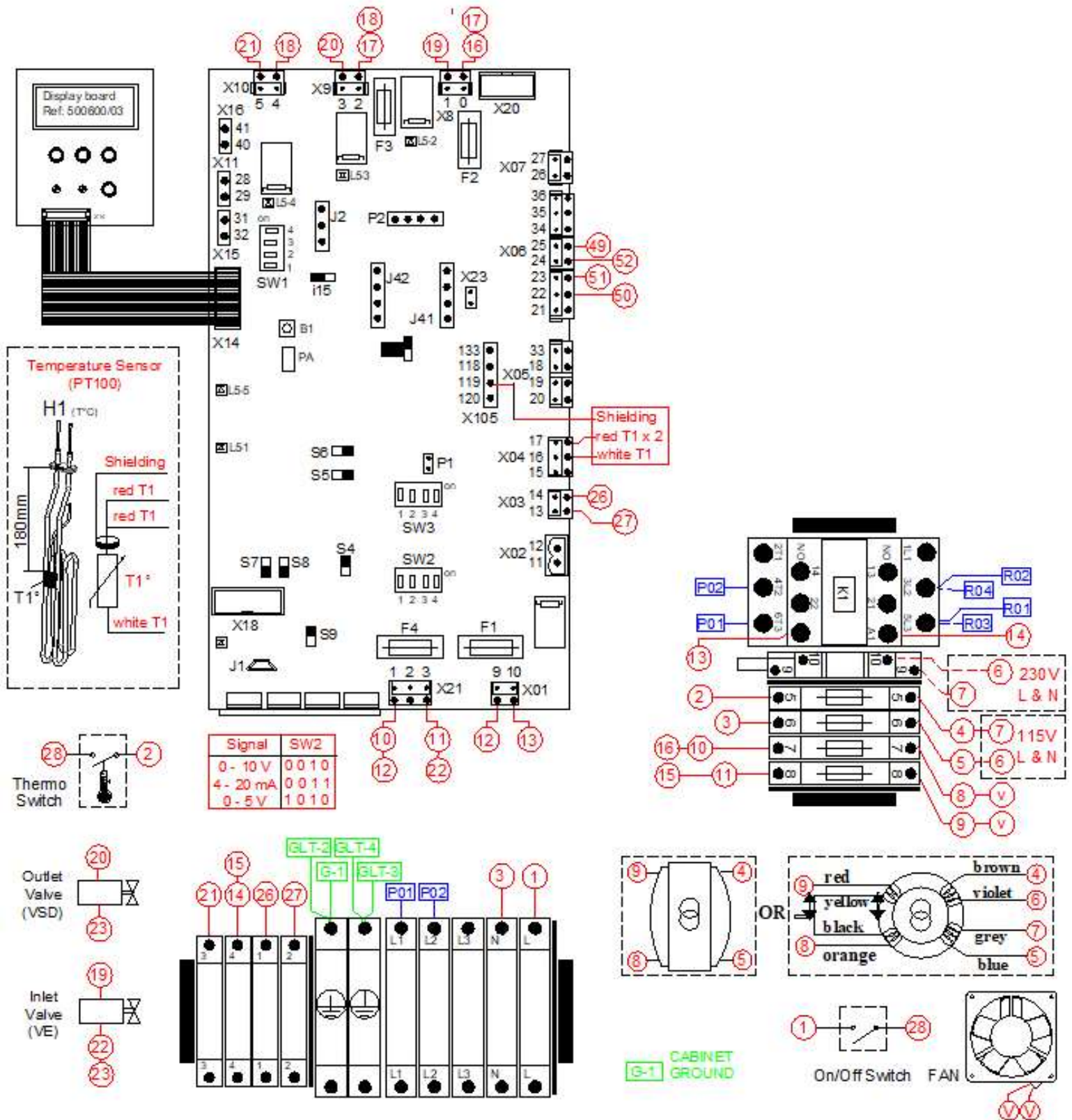

ELECTROVAP® RTH-LC

ON/OFF Range: Up[V] - 3x200-240V 50-60Hz (UL standard device not concerned)

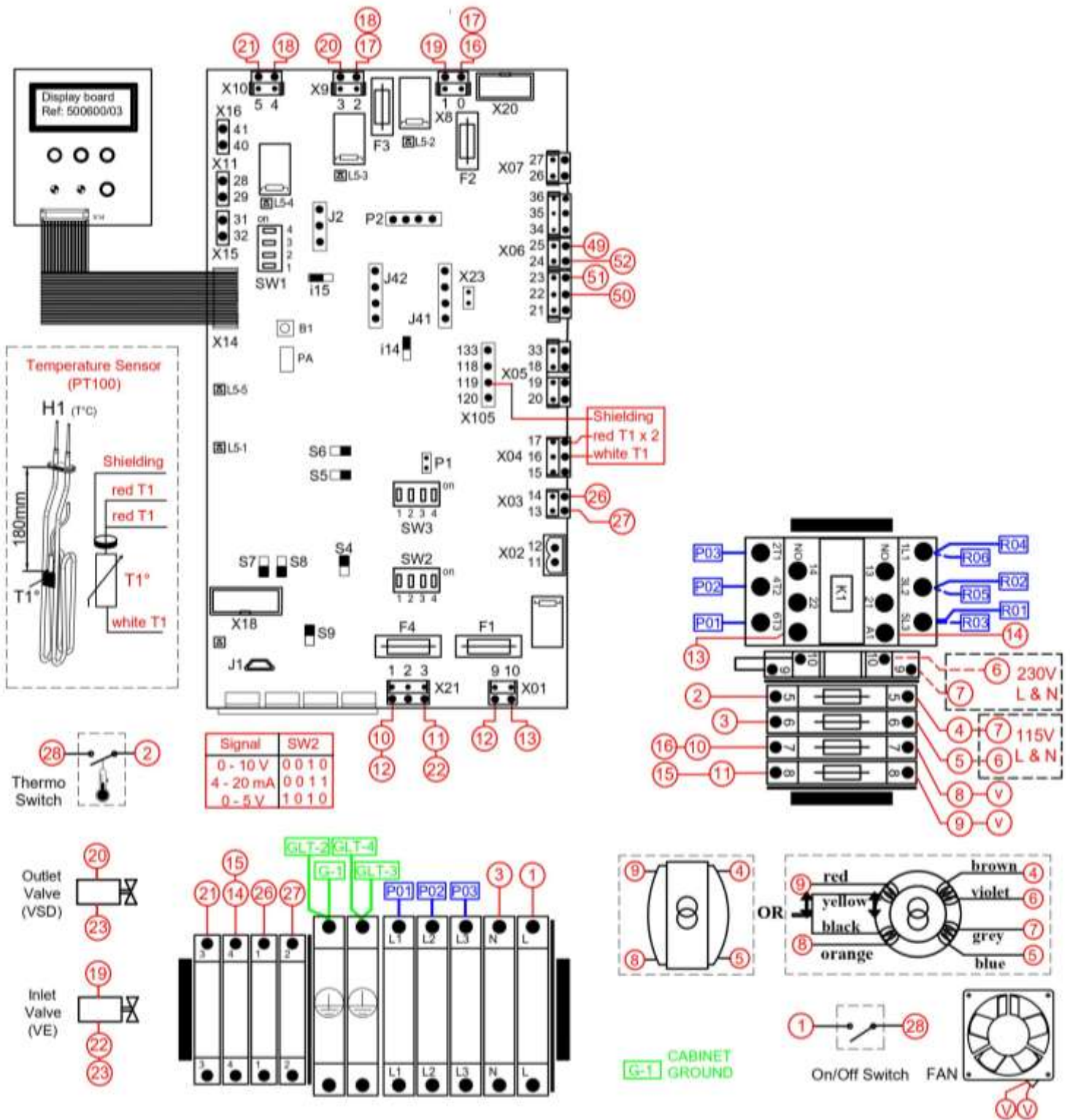

ELECTROVAP® RTH-LC

ON/OFF Range: Up[V] - 3x380-690V 50-60Hz (UL standard device not concerned)

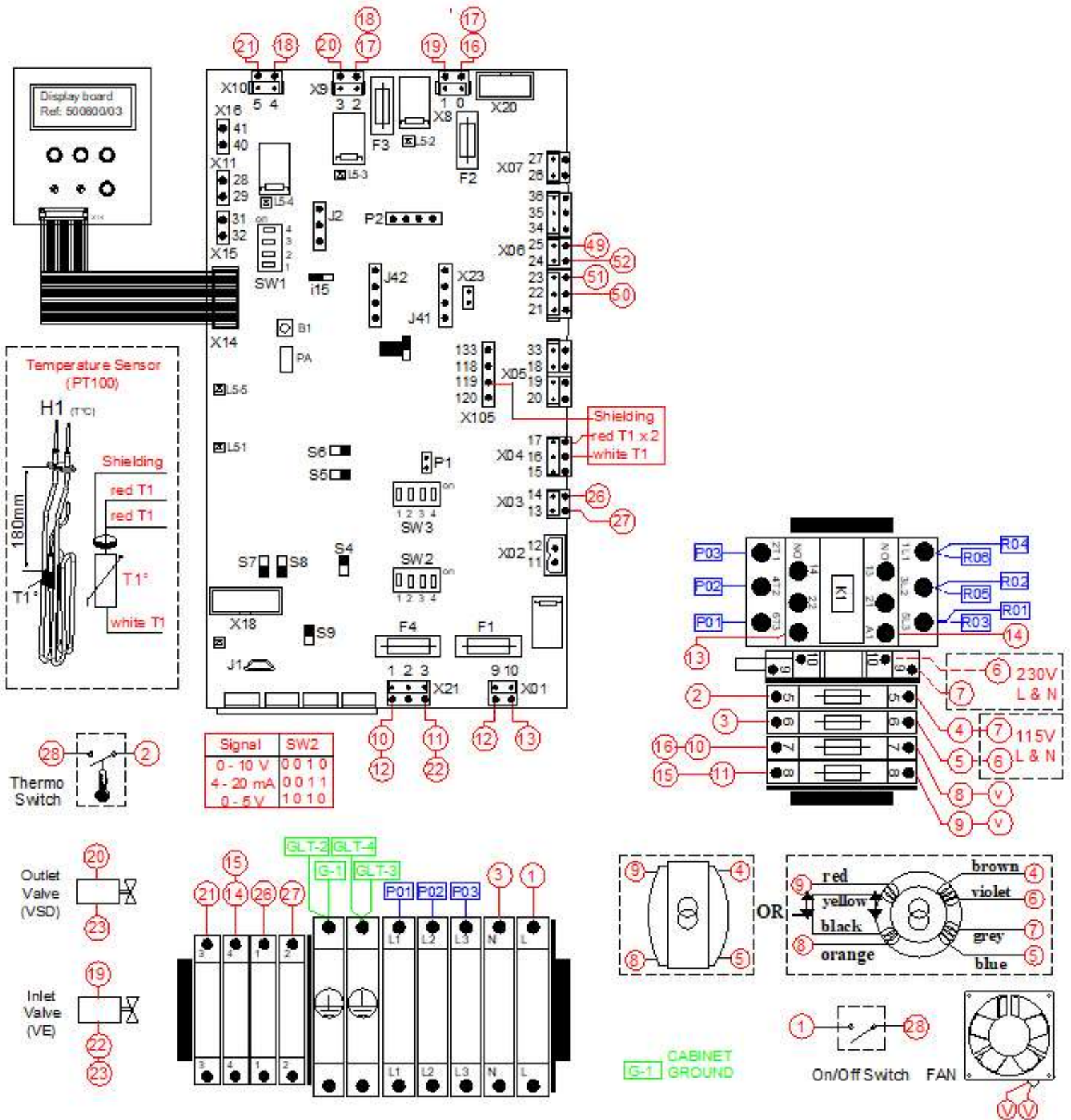

Signal	SW2
0 - 10 V	0 0 1 0
4 - 20 mA	0 0 1 1
0 - 5 V	1 0 1 0

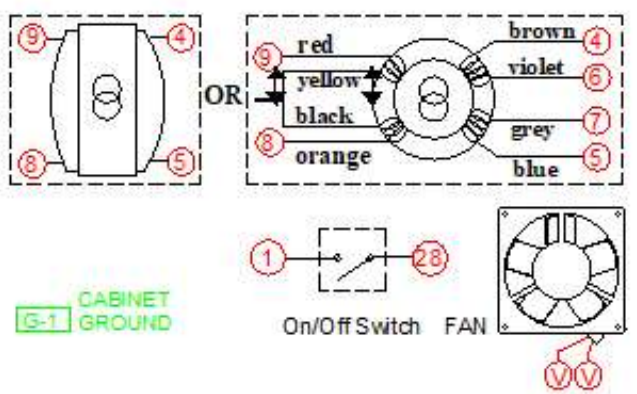
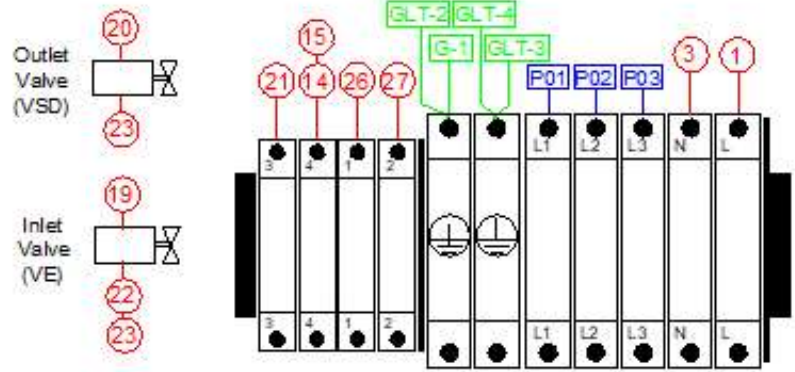
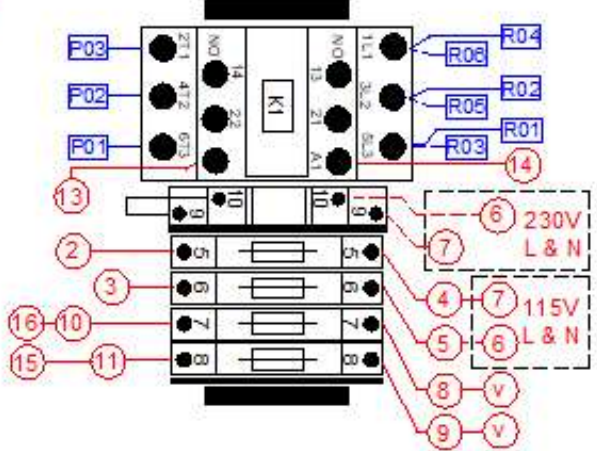

ELECTROVAP® RTH-LC

3.11 HEATING ELEMENTS WIRING DIAGRAMS

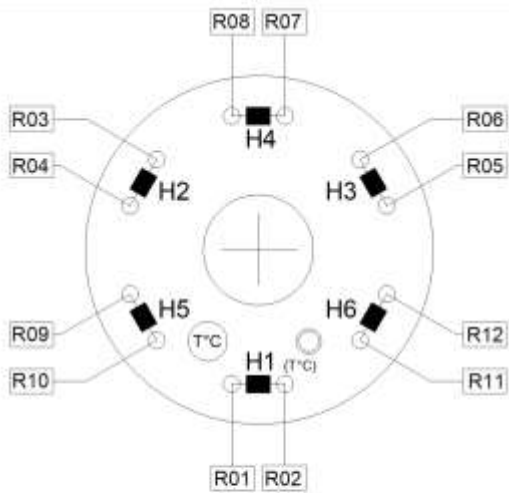

Case 1: Up[V] - 1x200-240V 50-60Hz

RTH	TANK		
	U(V)	H1	H2
3	1x200 - 240V	1,9K 230V	-
5	1x200 - 240V	4,3k 230V	-
8	1x200 - 240V	4,3k 230V	1,9k 230V

Case 2: Up[V] - 3x200-240V 50-60Hz

RTH	TANK			
	U(V)	H1	H2	H3
8	3x200 - 240V	1,9K 230V	1,9K 230V	1,9K 230V
18	3x200 - 240V	4,3k 230V	4,3k 230V	4,3k 230V

ELECTROVAP® RTH-LC

Case 3: Up[V] - 3x380-690V 50-60Hz

TANK							
RTH	U(V)	H1	H2	H3	H4	H5	H6
5	3x380 - 415V	1,9K 277V	1,9K 277V	1, 9K 277V	-	-	-
7	3x380 - 415V	1,9K 230V	1,9K 230V	1,9K 230V	-	-	-
	3x440 - 480V	1,9K 277V	1,9K 277V	1,9K 277V	-	-	-
	3x575 - 615V	1,9K 346V	1,9K 346V	1,9K 346V	-	-	-
	3x690V	1,9K 398V	1,9K 398V	1,9K 398V	-	-	-
10	3x380 - 415V	4,3K 277V	4,3K 277V	4,3K 277V	-	-	-
15	3x380 - 415V	4,3K 230V	4,3K 230V	4,3K 230V	-	-	-
	3x440 - 480V	4,3K 277V	4,3K 277V	4,3K 277V	-	-	-
	3x575 - 615V	4,3K 346V	4,3K 346V	4,3K 346V	-	-	-
	3x690V	4,3K 398V	4,3K 398V	4,3K 398V	-	-	-
20	3x380 - 415V	4,3K 277V	4,3K 277V	4,3K 277V	4,3K 277V	4,3K 277V	4,3K 277V
	3x440 - 480V	4,3K 277V	4,3K 277V	4,3K 277V	4,3K 277V	4,3K 277V	4,3K 277V
	3x575 - 615V	4,3K 346V	4,3K 346V	4,3K 346V	4,3K 346V	4,3K 346V	4,3K 346V
	3x690V	4,3K 398V	4,3K 398V	4,3K 398V	4,3K 398V	4,3K 398V	4,3K 398V
30	3x380 - 415V	4,3K 230V	4,3K 230V	4,3K 230V	4,3K 277V	4,3K 277V	4,3K 277V
	3x440 - 480V	4,3K 277V	4,3K 277V	4,3K 277V	4,3K 277V	4,3K 277V	4,3K 277V
	3x575 - 615V	4,3K 346V	4,3K 346V	4,3K 346V	4,3K 346V	4,3K 346V	4,3K 346V
	3x690V	4,3K 398V	4,3K 398V	4,3K 398V	4,3K 398V	4,3K 398V	4,3K 398V

ELECTROVAP® RTH-LC

3.12 WATER LEVEL DETECTOR WIRING

- 49: Common cable float detector
- 50: Low level
- 51: Intermediate level
- 52: High level

Fig. C 3-12. FLOAT LEVEL DETECTOR

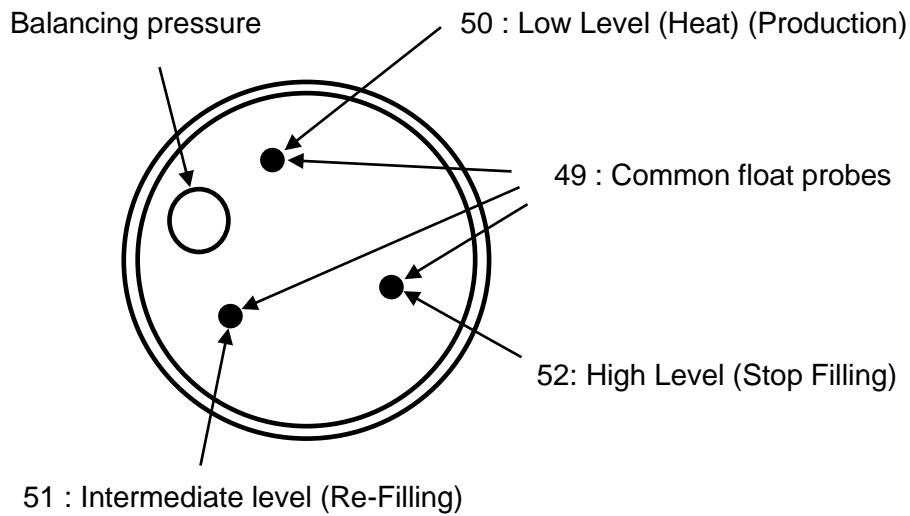
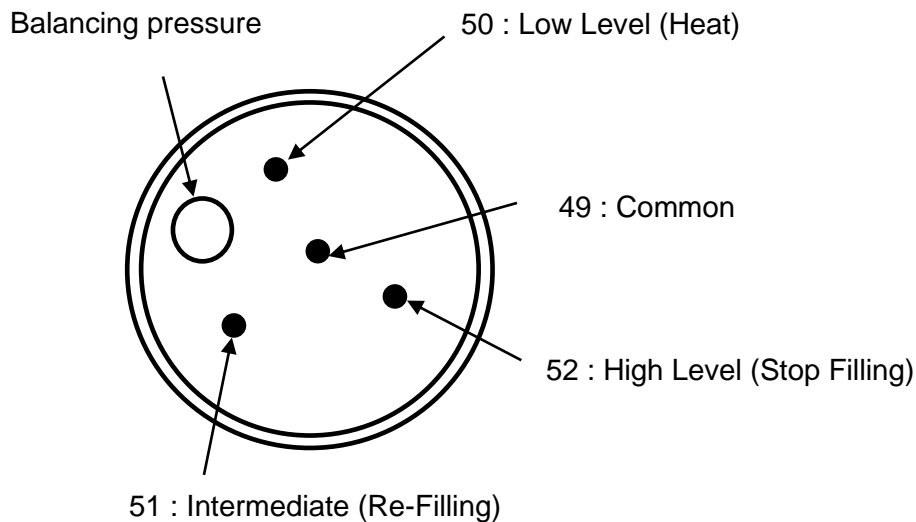

Fig. D 3-12. (OPTION) ELECTRODES LEVEL DETECTOR



ELECTROVAP® RTH-LC

3.13 OPTION: TRANSFORMER CONNECTION

Supply: L and N = 230 Vac

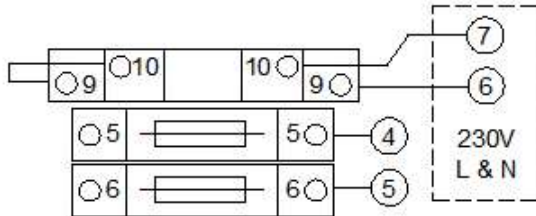

Supply: L and N = 115 Vac

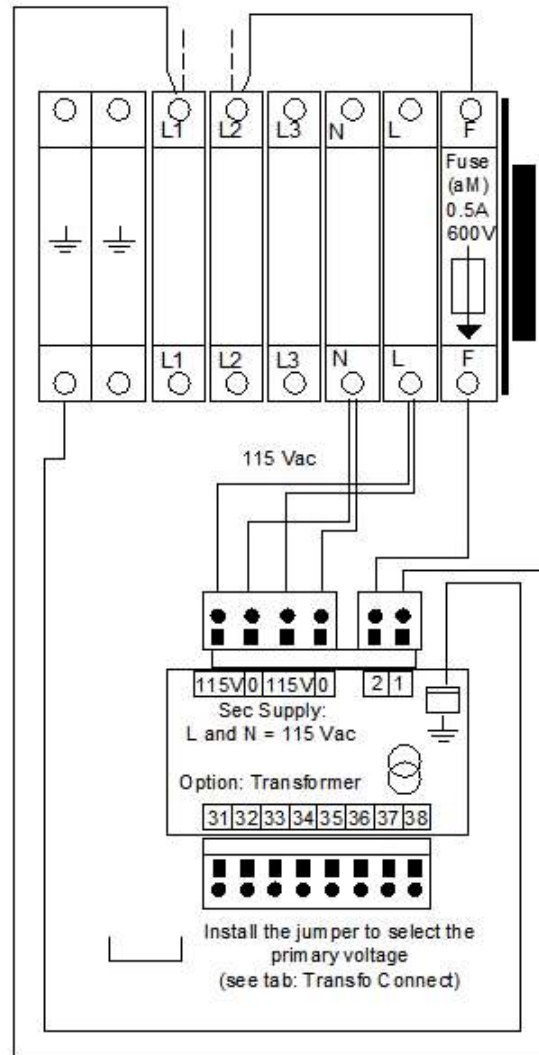
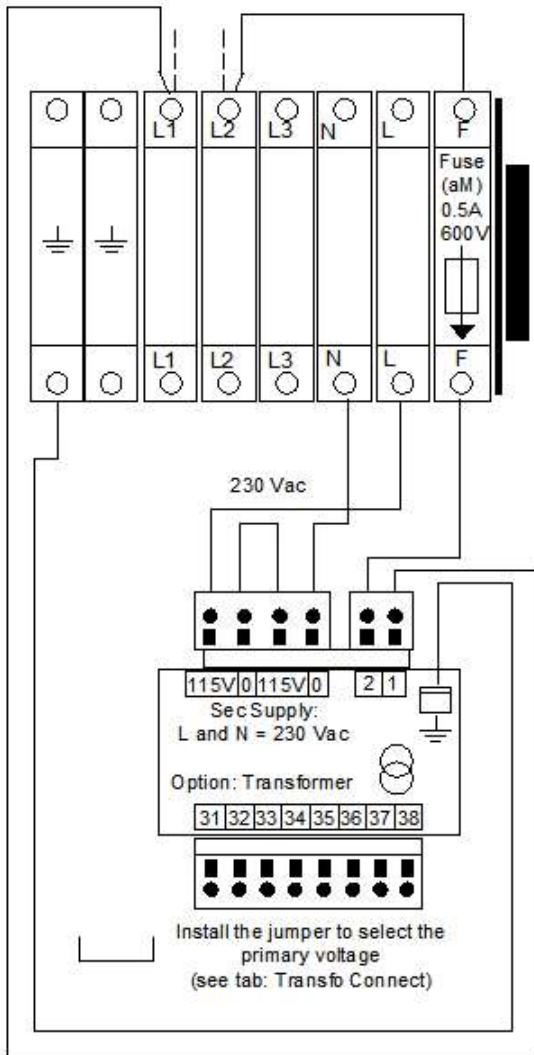
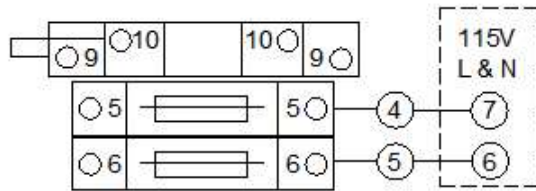

Primary voltage	600V	575V	480V	460V	440V	415V	400V	380V
Jumper position	34-35	33-35	33-36	32-36	32-37	31-37	32-38	31-38

Tab: Transfo Connect

ELECTROVAP® RTH-LC

4. COMMISSIONING



Before operation, please check that your installation complies with the manufacturer's technical recommendations. Check all power cables electrical connections. Remove the blocking blue foam ring from the tank.

Marker 1: Validation & change menu button
Marker 2: Upward button
Marker 3: Downward button
Marker 4: Manual drain button for maintenance
Marker 5: LED = Steam production indication

- Open the main water supply valve.
- Switch on the main power supply (power and control voltages).
- Switch on the unit switch.
- If the unit asks you for a commissioning code, note the serial number on the nameplate and contact your agent to obtain this code.
- Enter your three-digit code by doing this:
Press one of the keys 1, 2, 3 and the display will show you 0XX, with the flashing zero to eventually change it by pressing 2 or 3.
Once arrived at your digit, validate it by pressing key 1 and your second digit flashes. Repeat the previous two operations to show the last two digits.

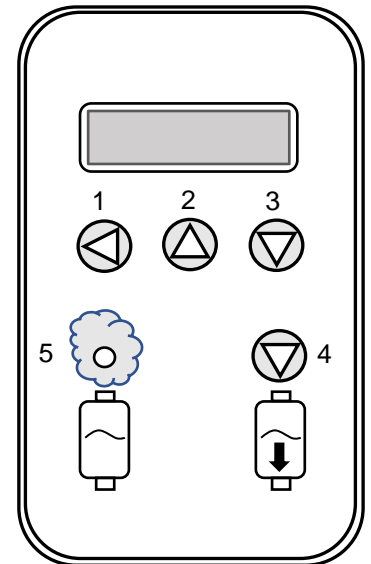

Fig. 4 Humidifier display

Very important: don't forget to validate the last digit.

- Enter water quality in the displayed menu.
- The device is ready to respond any production request.
- During steam production, the LED (5) lights up.

ELECTROVAP® RTH-LC

5. SYSTEM MANAGEMENT

5.1 MENU INFORMATION (READ ONLY)

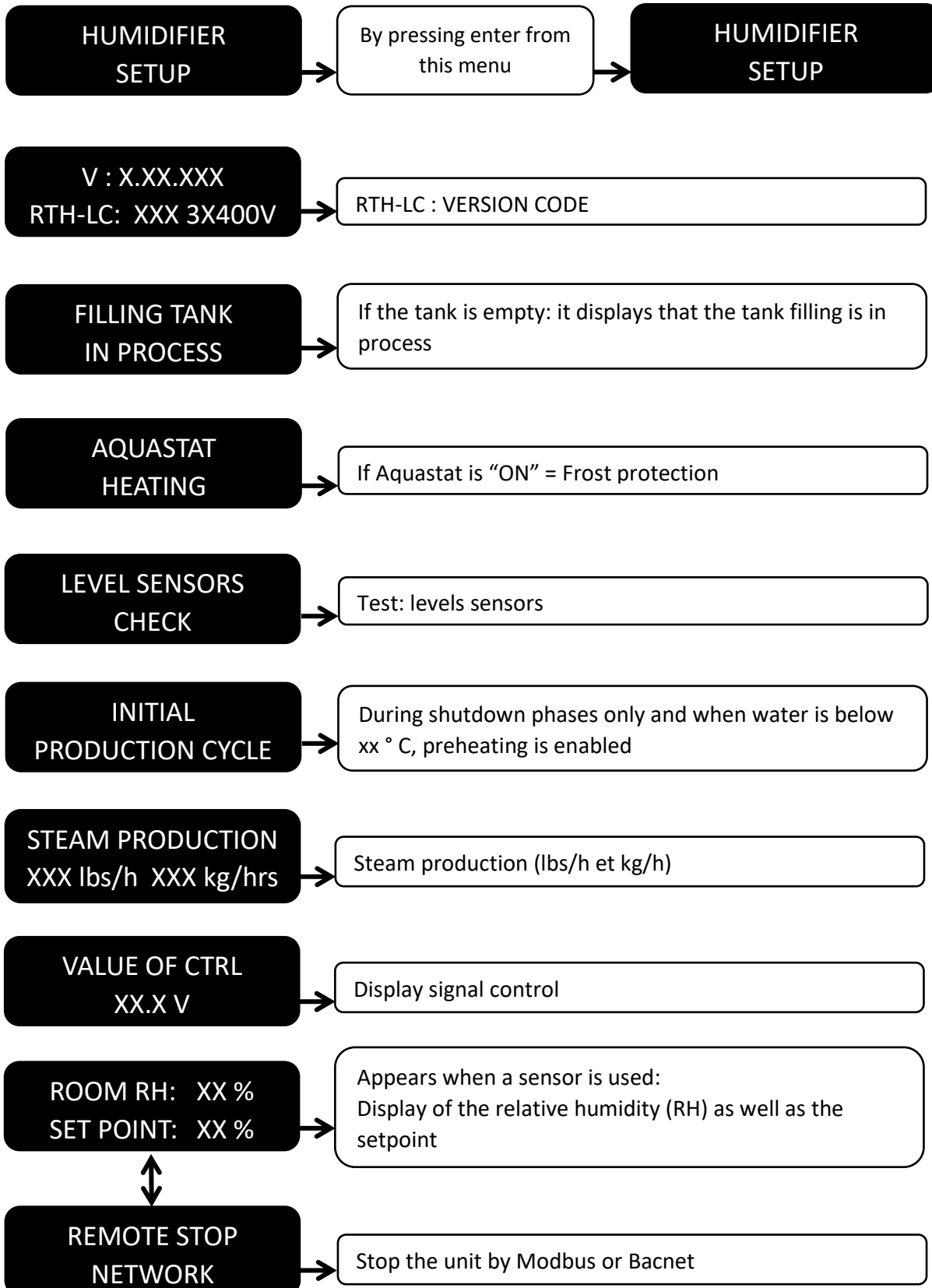

ELECTROVAP® RTH-LC

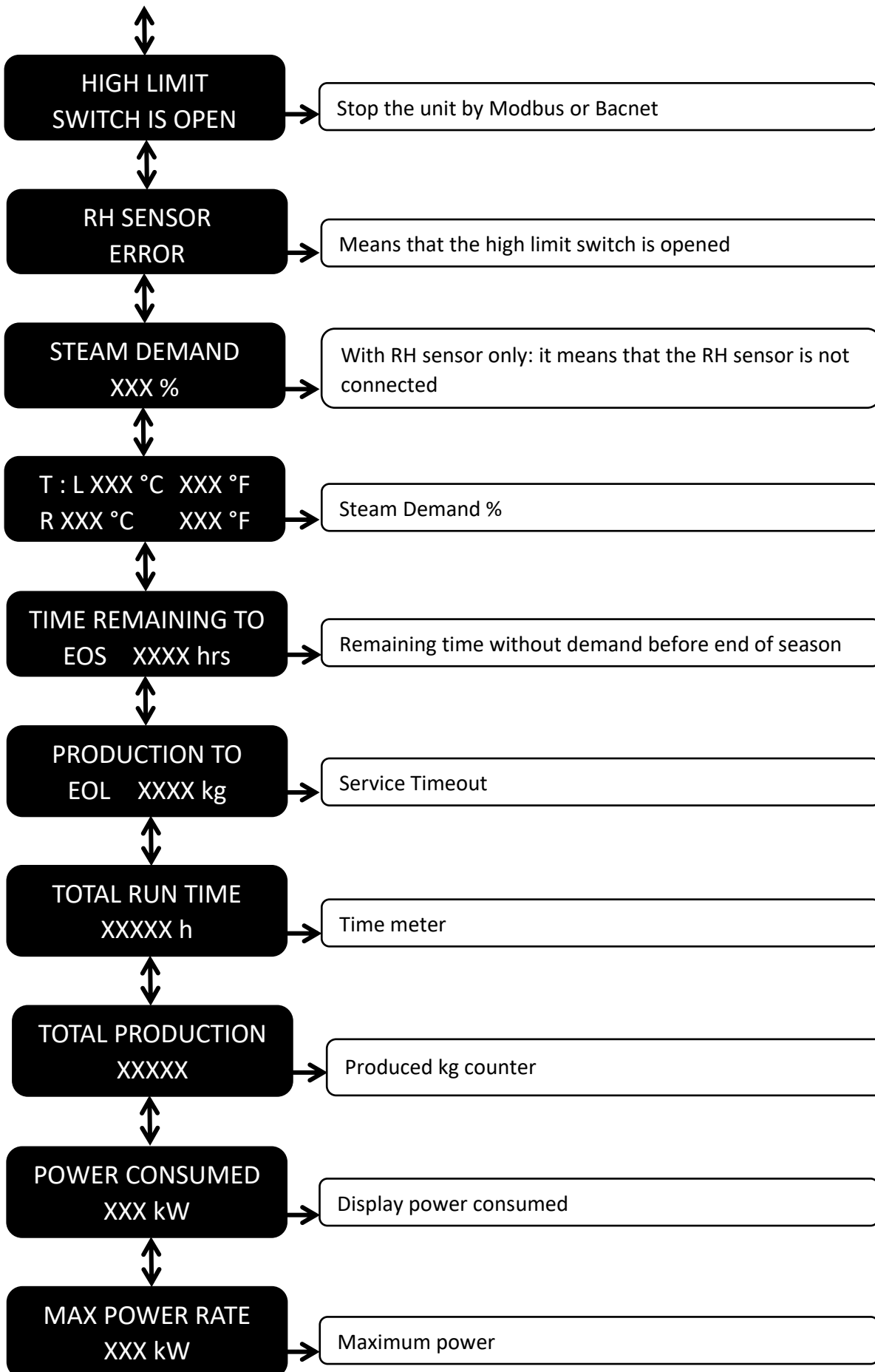

ELECTROVAP® RTH-LC

5.2 SETUP MENU

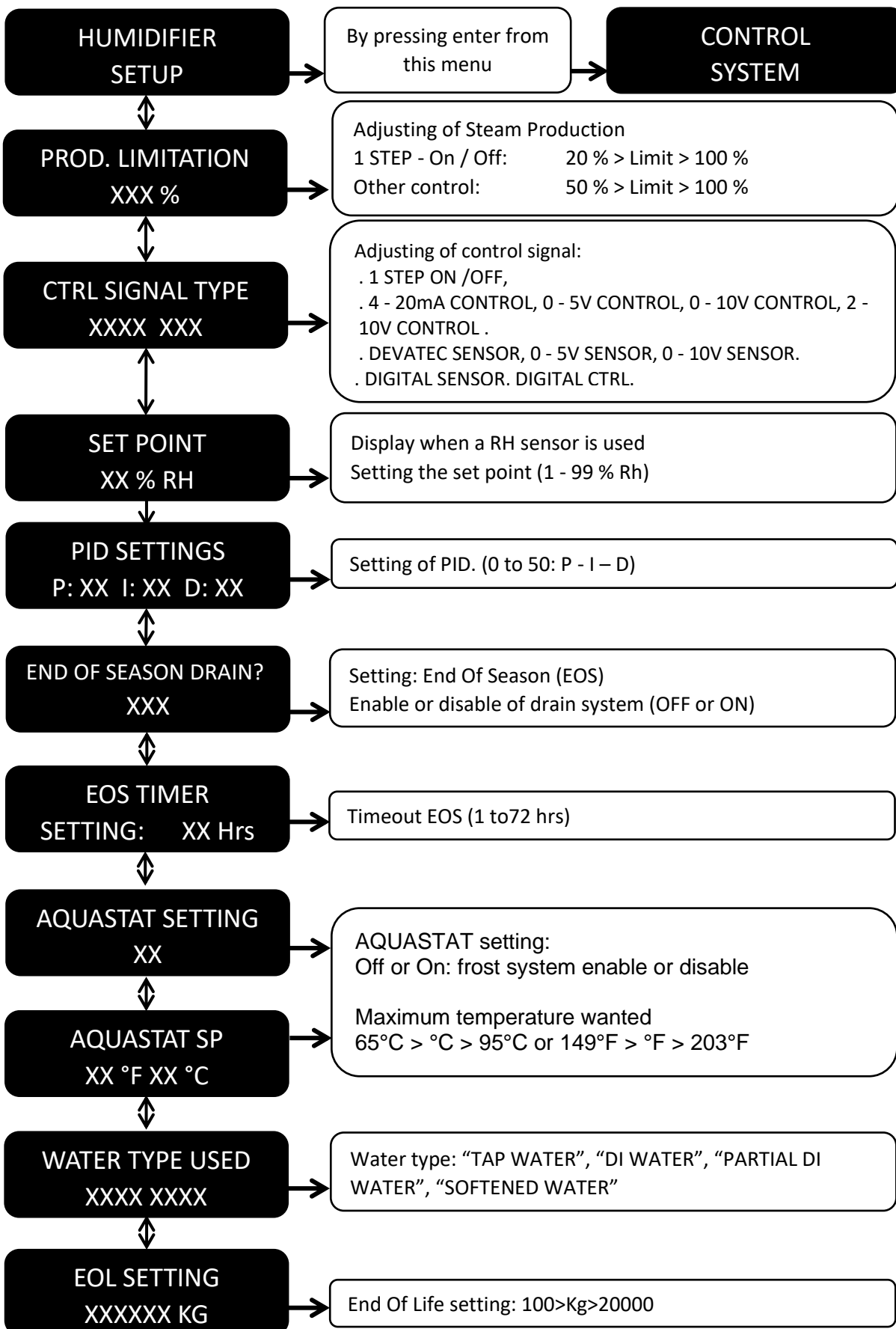

ELECTROVAP® RTH-LC

5.3 CONTROL SYSTEM MENU

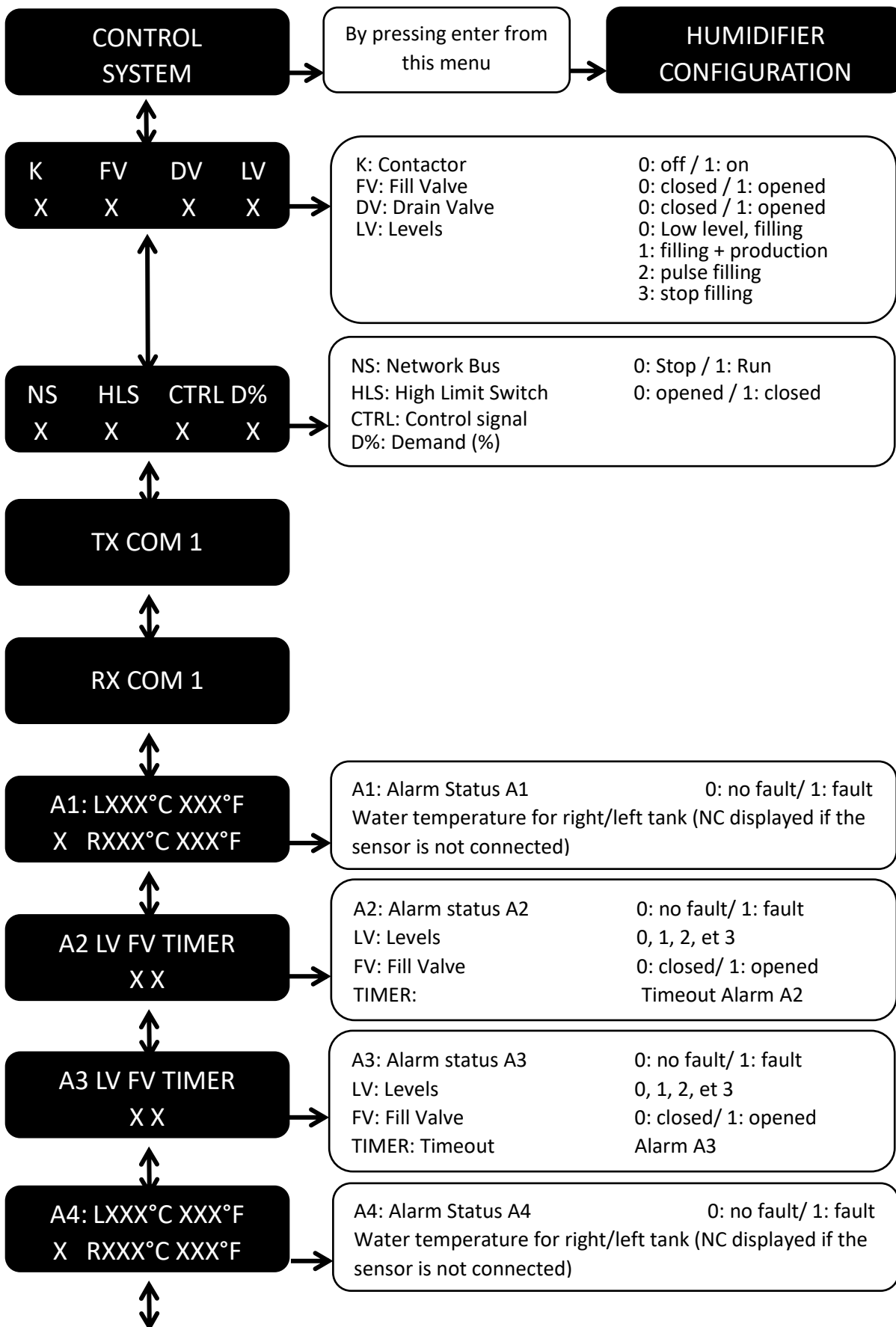

ELECTROVAP® RTH-LC

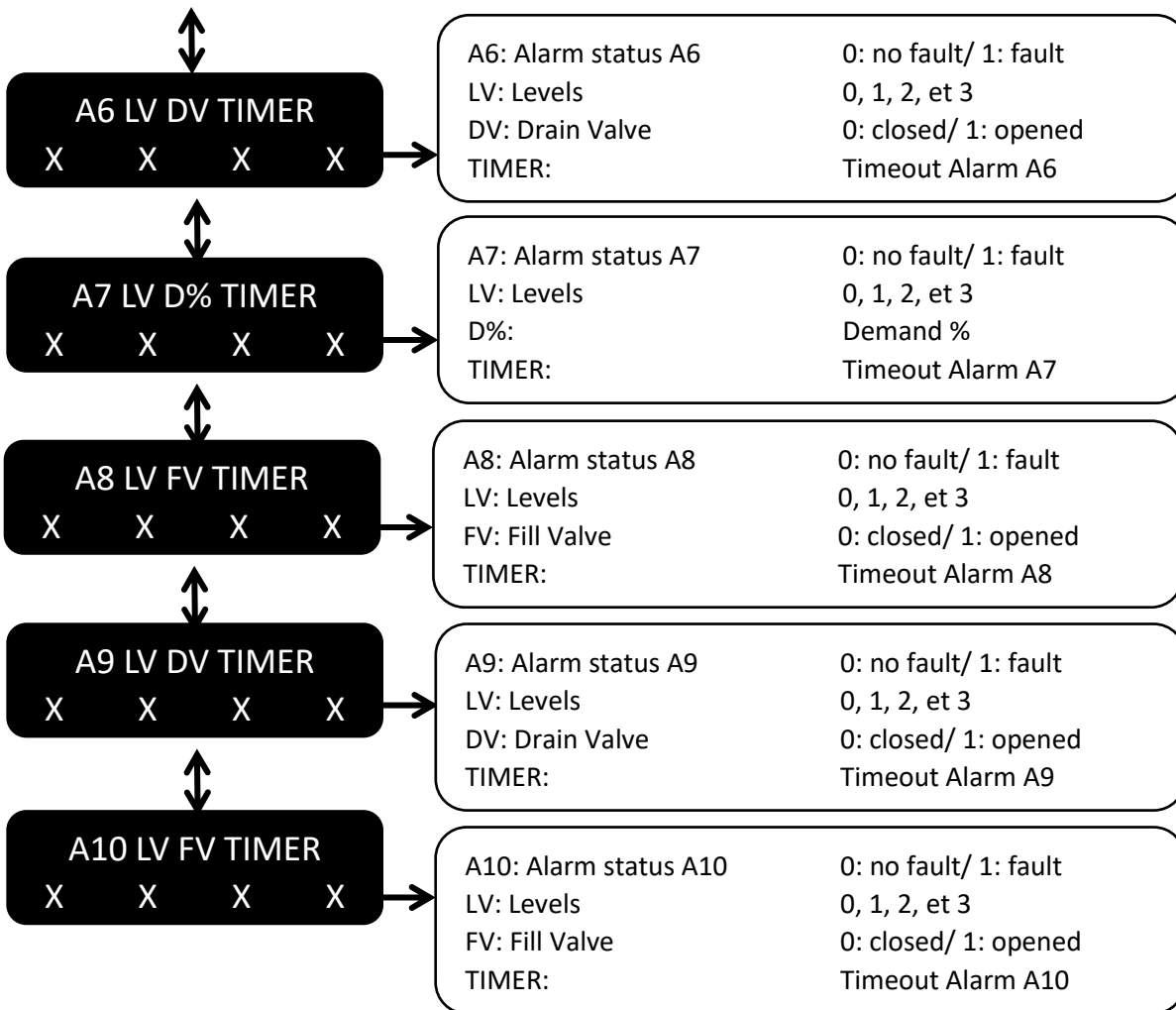

ELECTROVAP® RTH-LC

5.4 CHANGE SETTINGS MENU

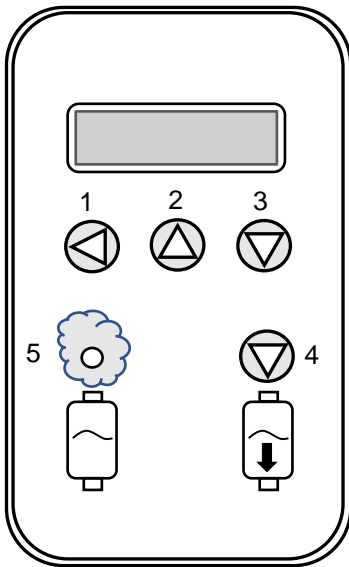

Procedure to enter the access code:

- Press the "1" key: the first cross flashes.
- Press the "2" key to increase the digit or the "3" key to decrease it.
- Once you have reached the desired digit of the code, press the "1" key to validate it: the 2nd cross flashes.
- Proceed in the same way for the following digits, and do not forget to validate the code by pressing the "1" key.

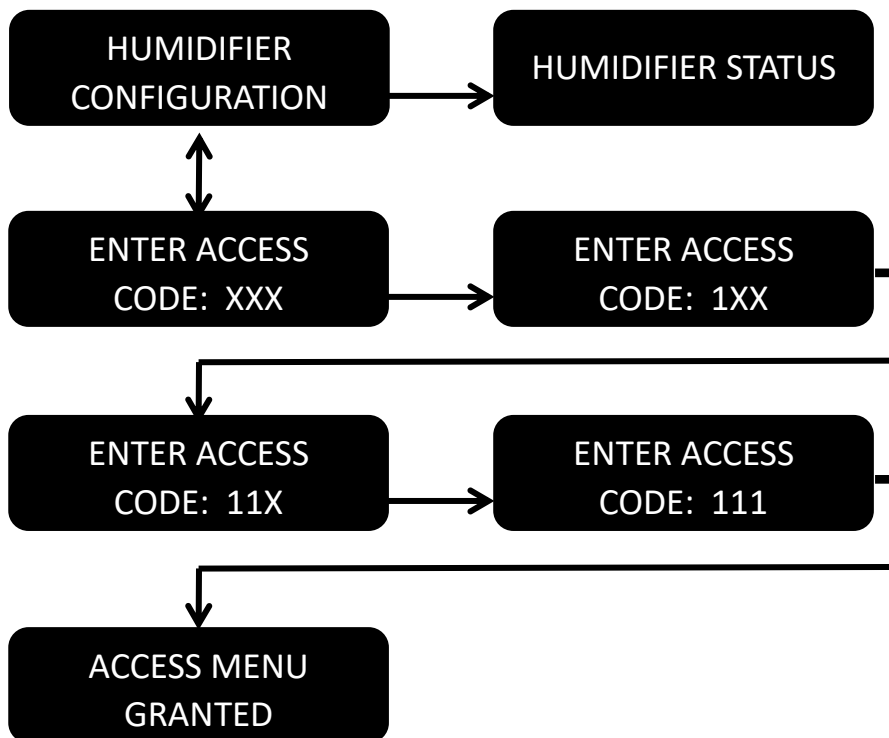

ELECTROVAP® RTH-LC

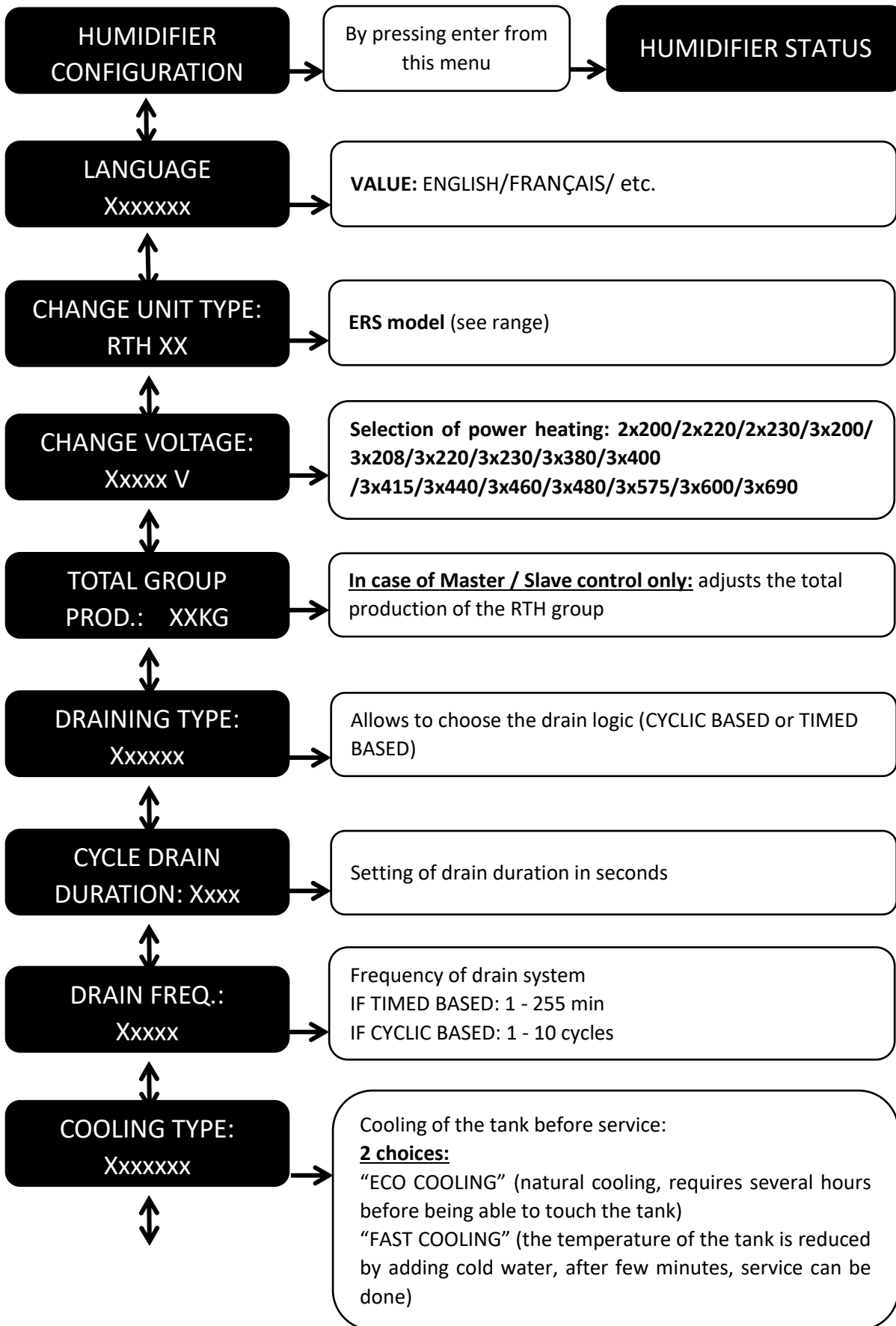

ELECTROVAP® RTH-LC

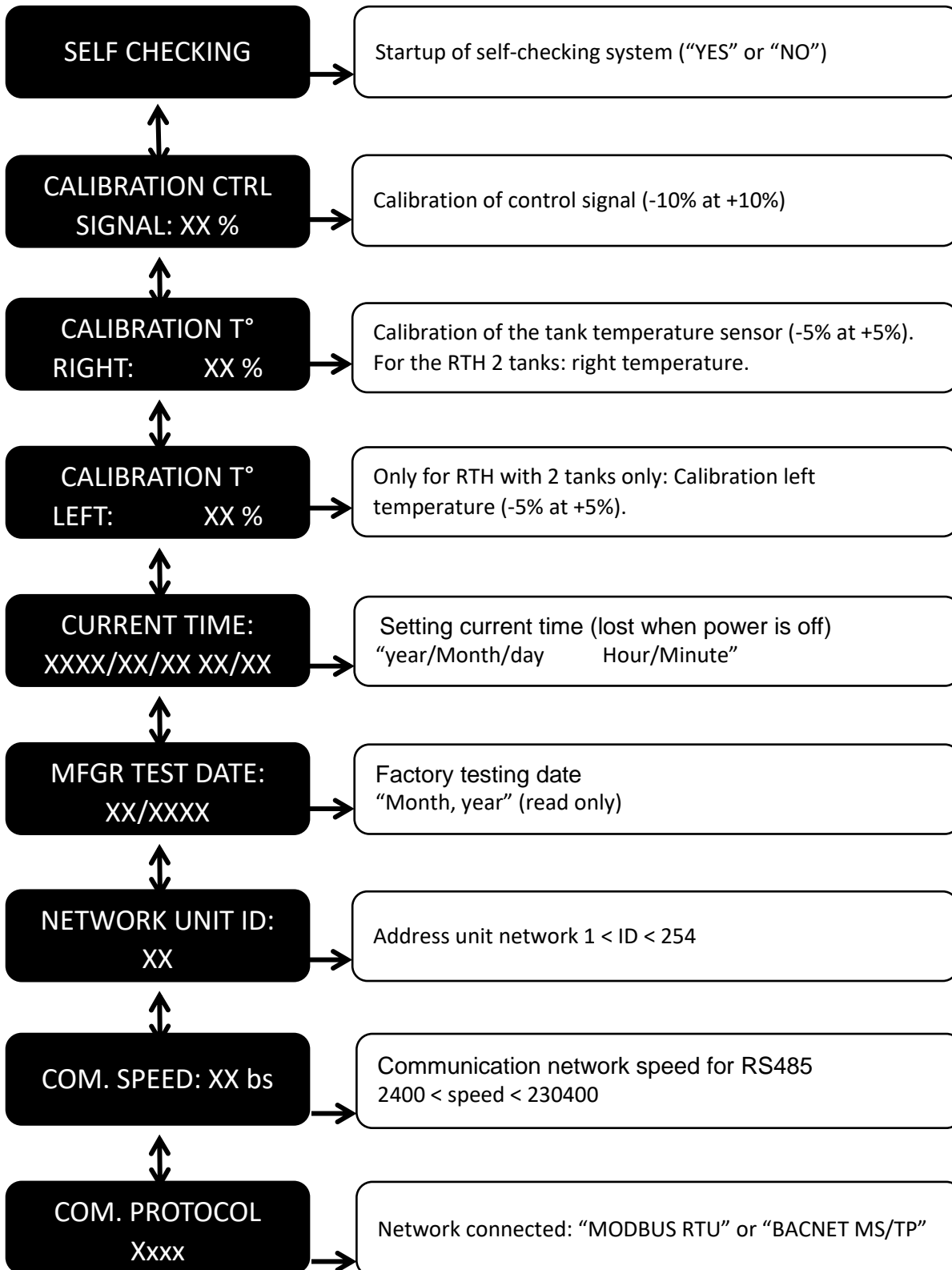

ELECTROVAP® RTH-LC

5.5 MAINTENANCE ALERTS

**M1: CHECKING 50hr
DUE**

This message is displayed 50 hours after the first start-up. It is then necessary to check the tightness of the electrical and hydraulic connections (steam pipe, drain circuit, water supply, etc.). The device is not stopped.

**M2: MAINTENANCE
DUE**

The maintenance timer has arrived at 0, it is necessary to maintain the device. The device is not stopped.

**M3: SERVICE OVER
DUE: DRAINING**

**M3: SERVICE OVER
DUE: COOLING**

**M3: SERVICE OVER
DUE: STOP UNIT**

The message M3 is displayed when the M2 display is displayed and 100 hours have elapsed without maintenance.

Then the unit is shut down, drained, the tank cooled, and put on hold of mandatory maintenance.

**MANUAL DRAIN IN
PROCESS**

This message is displayed once after pressing the manual drain button. The drain is activated.

**COOLING CYCLE
IN PROCESS**

This means that the manual drain is complete, and you must wait for the tank temperature to go down before servicing.

**MAINTENANCE
DUE**

The tank is empty and cooled, maintenance can be done. See technical manual.

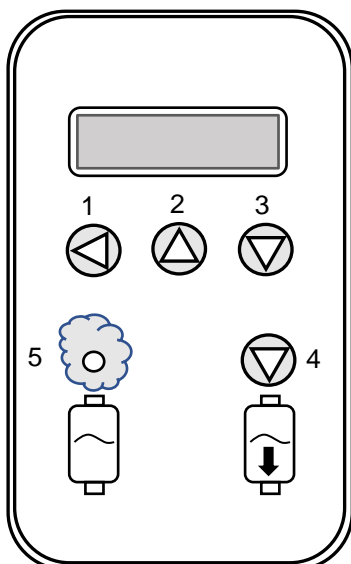

TO CARRY OUT A RESET FOR THE ABOVE MESSAGES, FOLLOW THIS PROCEDURE:

- Switch the unit to drain by pressing the manual drain button (4).
- Press button 3 for at least 5 seconds.

ELECTROVAP® RTH-LC

5.6 DEFAULT MESSAGE

A1: TANK TEMP. OVER-HEAT	Meaning: The temperature inside the tank is too high: 110 °C. The heating elements are no longer completely immersed.
	In this case: When this message appears, the tank is drained, the general fault contact is activated, and the unit is then stopped.

Possible causes and resolutions:

1. **Poor water supply from the tank.** A block of limestone obstructs the tank water inlet. The tank must be cleaned.
2. **Level sensor issue.** Check the correct electrical connection between the level sensor and the main board (see wiring diagrams, pg. 29). Floats visual checking and cleaning if needed.
3. **Defective temperature sensor or calibration to be redone.** If this message appears when the tank is cold, the temperature sensor (PT100) must be tested and replaced if necessary. Then contact your agent to recalibrate.
4. **Water quality issue.** Foam occurs in the tank; the purging time must be increased. From the "CHANGE PARAMETERS" menu find the "DRAIN TYPE" menu and activate the mode: "TIMED". Also check the regeneration times of the softener if it is supplied with softened water.
5. **Electronic issue.** Replace the main board and check that there is no steam or water flow in the electrical compartment.

ELECTROVAP® RTH-LC

A2: DEFECTIVE TANK FILLING	Meaning: The filling of the tank is not carried out correctly. The water level does not reach the low water detection level. (Maximum duration of filling before alarm: 20 min).
A3: FILLING PRODUCTION AREA	Meaning: No filling between low level and intermediate level.
A8: WATER RE-FILL DEFAULT	Meaning: No filling between intermediate level and high level.

In this case:

When this message appears, the tank is drained, the general fault contact is activated, and the unit is then stopped.

Possible causes and resolutions:

1. **Check water supply.** The pressure must be constant and between 2 and 8 bar. If in doubt, install a pressure regulator set at 2 bar on the supply pipe. Also check the condition of the water inlet valve, the electrical connection and the condition of fuse F2 (2A). Change the valve and fuse if defective.
2. **Blue hose inside the filling cup incorrectly positioned or pinched.** Replace the hose as shown in the picture.
3. **Check for proper condensate drainage.** Must absolutely be drained, otherwise it will accumulate in the steam hose, creating water projections and pressure rise in the tank, preventing the unit from being filled.
4. **Verify that the bleed valve is properly closed.** A piece of scale can block the valve closure and cause a leak, preventing proper filling of the unit.
5. **Electronic issue.** Replace the main board and check that there is no steam or water flow in the electrical compartment.

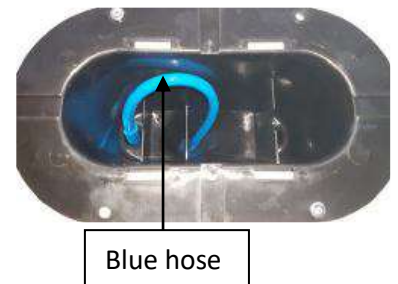

ELECTROVAP® RTH-LC

A4: TEMP. SENSOR DISCONNECTED	Meaning: The temperature sensor is either defective or disconnected.
	In this case: When this message appears, the tank is drained, the general fault contact is activated, and the unit is then stopped.

Possible causes and resolutions:

1. **Check the electrical connections.** The temperature sensor must be connected to the main board on connector X04 terminals 17 (2 red wires) and 16 (white wire). The ground wire is connected to connector X105 on terminal 49.

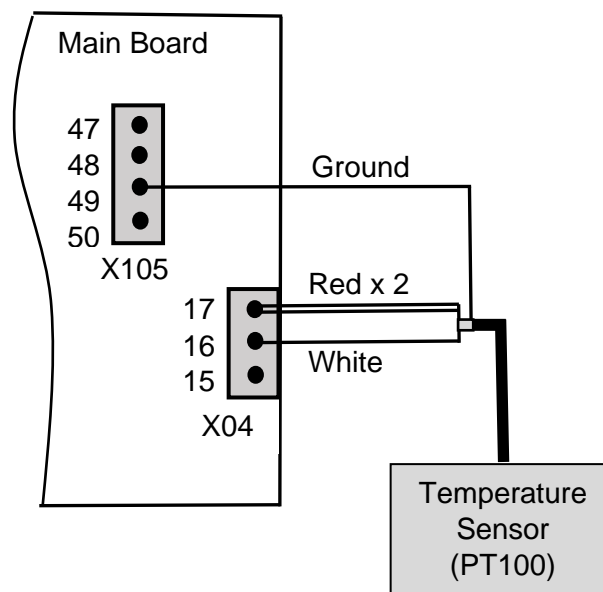

2. **Defective temperature sensor.** Disconnect the temperature sensor from connector X04. Use a multimeter to measure the resistance value of the PT100 at room temperature and compare this value with the PT100 resistance table.

If the value is different, the sensor is defective, replace the sensor.

3. **Electronic issue.** Replace the main board and check that there is no steam or water flow in the electrical compartment.

ELECTROVAP® RTH-LC

A6: HIGH LEVEL BLOCKED	Meaning: This means that the high level is continuously activated (time before detection: 14 minutes).
	In this case: When this message appears, the tank is drained, the general fault contact is activated and the unit is then stopped.

Possible causes and resolutions:

- 1. Level sensor issue.** Check the correct electrical connection between the level sensor and the main board (see wiring diagrams, pg. 29). Floats visual checking and cleaning if needed.
- 2. Electronic issue.** Replace the main board and check that there is no steam or water flow in the electrical compartment.

A7: VAPORIZATION TOO LONG	Meaning: Steam production is not enough.
	In this case: When this message appears, the tank is drained, the general fault contact is activated, and the unit is stopped.

Possible causes and resolutions:

- 1. Incorrect power supply.** Using a voltmeter, check supply voltage (Vac) on terminals L1, L2 and L3 of the heating elements). If the supply voltages are not identical, check the supply circuit up to each heating element and replace the defective components.
- 2. Continuous water supply.** Check water supply pressure ($2 > P \text{ (bar)} > 8$), replace filling valve if necessary.
- 3. Level sensor issue.** Check the correct electrical connection between the level sensor and the main board (see wiring diagrams, pg. 29). Floats visual checking and cleaning if needed.
- 4. Electronic issue.** Replace the main board and check that there is no steam or water flow in the electrical compartment.

ELECTROVAP® RTH-LC

A9: COMPLETE DRAIN TOO LONG	Meaning: Water drainage problem.
	In this case: When this message appears, the tank is drained, the general fault contact is activated, and the unit is then stopped.

Possible causes and resolutions:

1. **The drain circuit is clogged.** Press the "MANUAL DRAINING" button, and check for proper water flow. Perform the following maintenance: tank (pg. 54), drain valve (pg. 55) and level detector (pg. 56). Also remember to check that nothing is obstructing the drain pipe.
2. **Blown F3 fuse.** Replace F3 fuse, located on the main board, and the drain valve.
3. **Electronic issue.** Replace the main board and check that there is no steam or water flow in the electrical compartment.

A10-AX : LEVEL CHECK FAILED	Meaning: Problem with the water level detector or with the draining system.
	In this case: When this message appears, the tank is drained, the general fault contact is activated, and the unit is then stopped.

Possible causes and resolutions:

1. **A float level sensor is blocked.** Check and clean the water level detector.
2. **The drain valve is out of order and / or blown F3 fuse.** Replace F3 fuse, located on the main board, and the drain valve.
3. **The drain circuit is blocked.** Clean the drain circuit, tank, drain valve, drain hose, the collecting water tank (option))
4. **Electronic issue.** Replace the main board and check that there is no steam or water flow in the electrical compartment.

ELECTROVAP® RTH-LC

Black screen: Power switch On / display and unit Off after a potential overheat

	Meaning: Problem “Overheating” is detected by high temperature switch (this switch is installed on the lid of the tank)
	In this case: When this display is off, the control voltage is cut by the high temperature switch and the unit is stopped.

Possible causes and resolutions:

1. **An overheating in the tank has been detected.** Check the water level detector, the cables and the heating elements.
Replace the float sensor or / and the heating element out of order, the tank seal and the temperature sensor.

Once the problem is solved, press the reset button of high-temperature switch located on the cover of the tank.

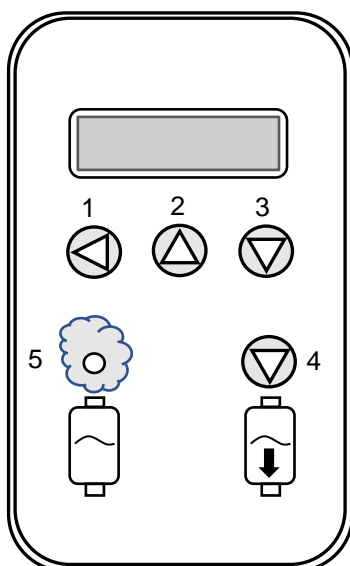
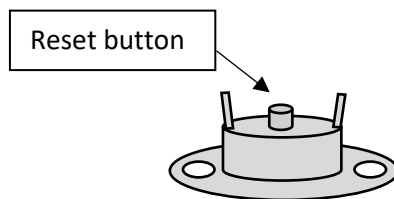

TO CARRY OUT A RESET FOR THE ABOVE MESSAGES, FOLLOW THIS PROCEDURE:

- Switch the unit to drain by pressing the manual drain button (4).
- Press button 3 for at least 5 seconds.

ELECTROVAP® RTH-LC

6. MAINTENANCE

6.1 STAINLESS STEEL TANK

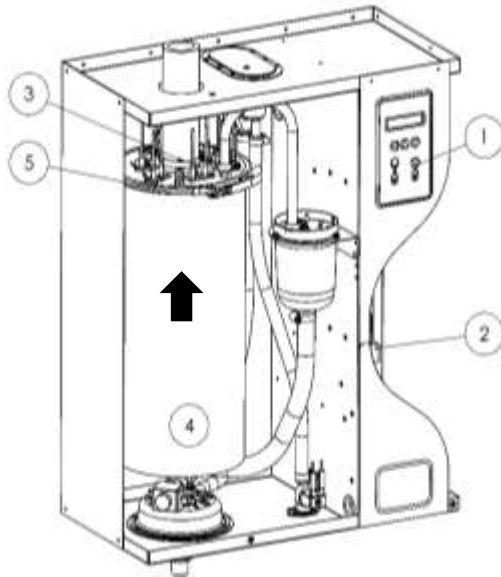

Fig. 6-1. Humidifier Stainless steel tank

- Drain the water by pressing the drain button (1). Wait for «DO MAINTENANCE » display.
- Cut the power supply to the power circuits (in the general electrical cabinet) and control circuits located on the side of the unit (2).
- Remove the door and unscrew the collar (3). Completely disconnect the steam hose and remove it from the unit.
- Pull out the steam tank by lifting it upwards (4) until its base is completely free.
- Pull the clamp handle towards you till the top of the tank is free (5).
- Remove the tank lid with the heating elements and place it on the top of the unit.
- Put a container or the optional flexible lime collecting bag on the ground and use it to empty the tank.
- Replace the tank lid with the heating elements and pay attention that no power wires be jammed between the tank and the device bottom.
- Before repositioning the tank in the unit, please check the presence of the drain valve seal.
- Finally, tighten the nuts on the tank cover and put the steam hose back on.

Take care: the tank gasket should be changed whenever the tank is maintained. Retighten all clamps.

Do not scratch harshly, hit or use corrosive liquids on the heating elements.

Very important:

- do not use solvents to clean the water level detector. If necessary, you can use a scraper to clean the level sensors. If you need to intervene on the detector, do not use special glues but only Teflon.

ELECTROVAP® RTH-LC

6.2 DRAIN VALVE

The drain valve should be maintained whenever the steam tank is maintained or changed.

- Once the tank is out of the humidifier, disconnect the drain valve supply cables **(Item 1)**.
- Unscrew the nut and the plastic protection of the supply coil **(Item 2 & 3)**.
- Now you can remove the coil (Item 4) from the valve body **(Item 5)**.
- Use a pair of pliers or a 19" wrench to unscrew the valve plug **(Item 6)** from the valve body **(Item 5)**.
- Check and clean, if necessary, the inside of the valve body by running water through the hole.

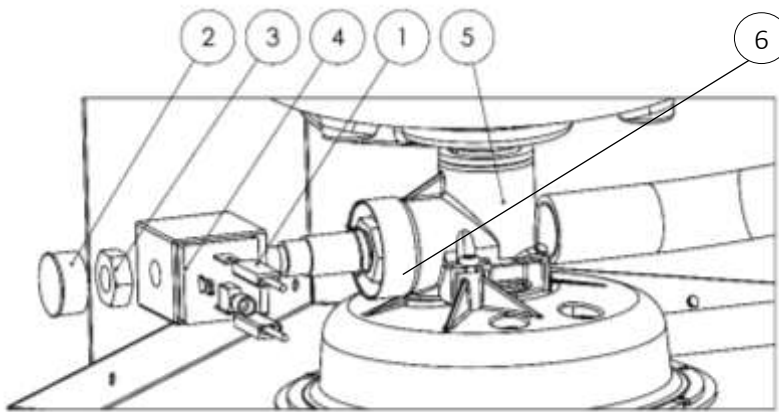

Fig. 6-2. Humidifier drain valve

Reassemble the drain valve as original, before repositioning the tank, by proceeding as follows:

1. Position the tank bottom in the valve connection, push down.
2. Replace the steam hose and do not forget to tighten the hose clamp.

Ensure that all the clamps are properly tightened whenever the humidifier is maintained.

ELECTROVAP® RTH-LC

6.3 WATER INLET VALVE

Maintenance of the water inlet valve is to be done after the first 50 hours of operation. Thereafter, twice a year (minimum).

- Switch the appliance off.
- Switch off the water supply to the humidifier and unscrew the water supply hose.
- Disconnect the power cables from the water inlet valve of your humidifier (Item 1).
- Loosen the clamp and remove the water supply hose. (Item 2)
- Unscrew the two screws securing the valve (Item 3).
- Pull out your valve, remove the filter with pliers and remove the coil (Item 4) by prying it off with a screwdriver.
- Run water through the valve body and over the filter to remove any particles.

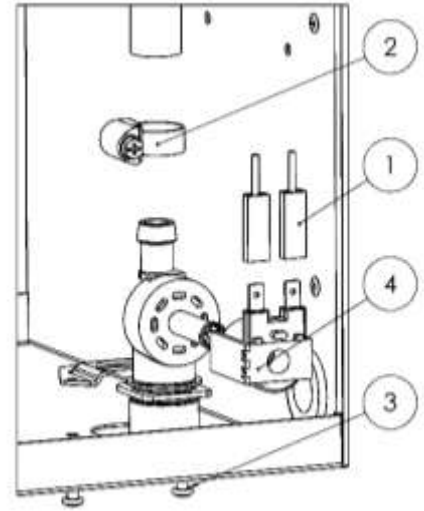

Fig. 6-3. Humidifier water inlet valve

Once all these operations completed, please reassemble the unit, taking care to check the condition of the water supply hose clamp. You can put your appliance back into service.

Ensure that all the clamps are properly tightened whenever the humidifier is maintained.

6.4 WATER LEVEL DETECTOR

Maintenance of the detector should be done during each tank maintenance.

- Disconnect the cables of the water level sensor (1).
- Unscrew the clamp of the pressure balancing tube (2) and disconnect it from the cover.
- To release the sensor, unscrew the hose clamp (3) and disconnect the hose. Caution, there may still be water inside the tube.
- Clean the hose without unscrewing it.
- Unscrew the 3 screws (4) in order to clean the floats and the body of the level sensor.



Fig. 6-4. Humidifier water level detector

ELECTROVAP® RTH-LC

7. SPARE PARTS

7.1 STAINLESS TANK

N°	Code	Description
1	D110828-SP	Cylinder clamp
2	D111781-SP	Heating element nut M5
3	D110830-SP	Heating element bracket
4	D110832-25-SP	Top with Ø 25mm outlet
	D110832-40-SP	Top with Ø 40mm outlet
5	D110829-SP	Cylinder seal
6	D110754-SP	High temperature switch
7	D110765-230-SP	Heating element 230V 1900W
	D110765-277-SP	Heating element 277V 1900W
	D110765-346-SP	Heating element 346V 1900W
	D110765-398-SP	Heating element 398V 1900W
	D110761-230-SP	Heating element 230V 4300W
	D110761-277-SP	Heating element 277V 4300W
	D110761-346-SP	Heating element 346V 4300W
	D110761-398-SP	Heating element 398V 4300W
8	D94058	Temperature sensor
9	D110205-SP	Drain filter
10	D110831-SP	Stainless steel cylinder

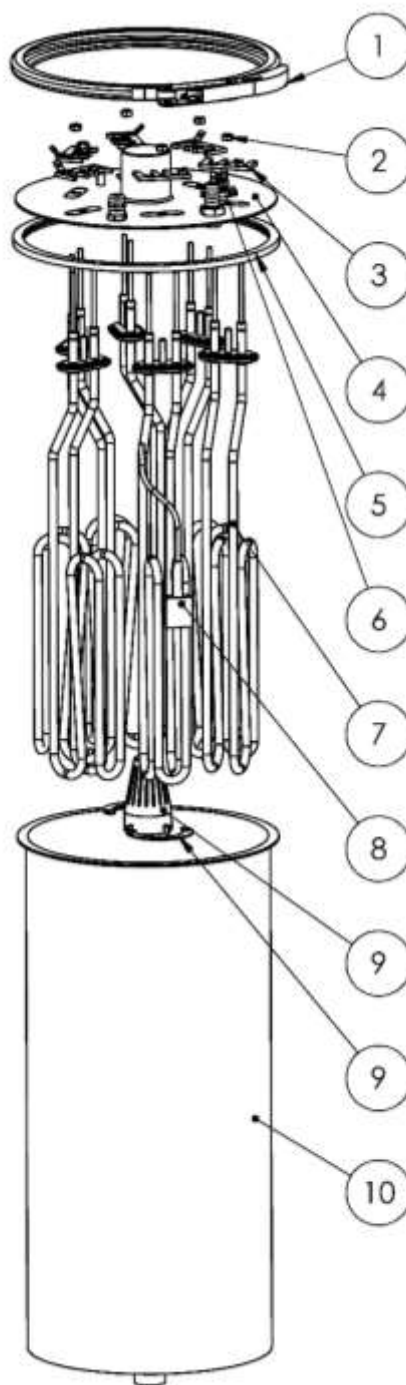

If the tank is completely changed, use the reference below:

Complete tank Voltage RTH-LC model

↓ ↓ ↓

D110808-3x400-30

Fig. 7-1. Tank exploded view

ELECTROVAP® RTH-LC

7.2 WATER INLET VALVE

N°	Code	Description
1-2	D110157-SP	Water inlet valve 3-30 kg/hr
2	D116645-24	Coil 24V
	D116645-24-UL	UL coil 24V
3	D111775-SP	Valve bracket

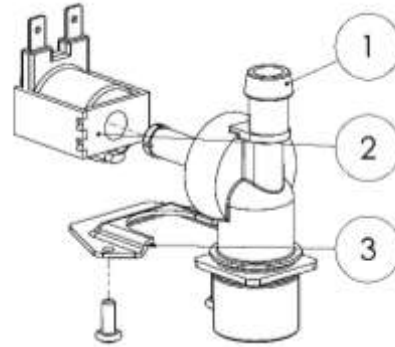

Fig. 7-2. Water inlet valve exploded view

7.3 WATER LEVEL DETECTOR

N°	Code	Description
1 - 4 & 6	D110232-DI-SP	Complete float water level detector
1		Polypropylene upper body
2		Flat gasket for float (set of 3)
3		Level sensor (set of 3)
4	D110734-SP	O-ring seal
5		Stainless steel sensor support
6		Polypropylene lower body

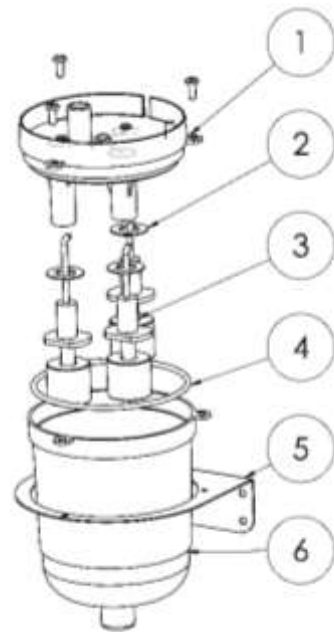

Fig. 7-3. Water level detector exploded view

7.4 DRAINING CIRCUIT

N°	Code	Description
1 - 5 & 8 - 10	D110147-SP	Complete valve (1 to 5)
1		Adapter ring
2		Protective ring
3	D110153-SP	O-ring seal (set of 10)
5	D110149-SP	Valve body
6	D110154-SP	Drain cup upper part
7	D110155-SP	Drain cup lower part
8	D110148-10-SP	Nut protection
9	D116656-24-SP	Drain valve coil
	D116656-24-UL-SP	UL drain valve coil
4 - 10	D110148-SP	Valve pilot kit 24vac
	D110148-UL-SP	Valve pilot kit 24vac (UL)

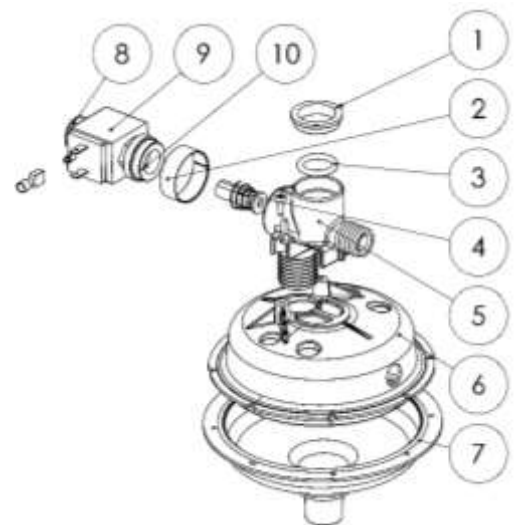

Fig. 7-4. Draining circuit exploded view

ELECTROVAP® RTH-LC

7.5 ELECTRICAL PART

N°	Code	Description
1	D110124-SP	Display board
2	D121388-5-SP	Main board RTH-LC (OTI)
3	D50931-SP	Remote information board
4	D109737-SP	Power terminal 35mm ² (L1, L2, L3)
5	D110168-SP	Control terminal 16mm ² (L, N)
6	D107491-SP	Terminal 2,5mm ² (1, 2, 3, 4)
7	D110163-SP	Ground terminal 35mm ² .
8	D110806-600-60-SP D110806-600-90-SP D110806-690-75-SP	Static relay RTH-LC 3 - 15 if Up[v] = 230-600V Static relay RTH-LC 20 - 30 if Up[v] = 230-600V Static relay RTH-LC 3 - 30 if Up[v] = 690V
9	D50932-SP	24V contactor
10	D110173-SP	Setting terminal 115/230V
11	D110768-SP	Fuse protection terminal 6mm ² .
12	D110166-SP	Stop terminal
13	D110128-50-SP	Control transformer Prim :2x115V Sec :2x12V
14	D92393-SP	On/Off switch
	D116631-SP	Fast Fuse 2A - 5x20 mm (Bag of 6)
	D116718-SP	Fast fuse 5A - 5x20 mm (Bag of 6)

Location	Amp.	Fuse protection
F1	2AT	Power contactor coil
F2	2AT	Inlet valve coil
F3	2AT	Drain valve coil
F4	2AT	Electronic boards
Din rail 5 & 6	2AT	Transformer
Din rail 7 & 8	5AT	Transformer

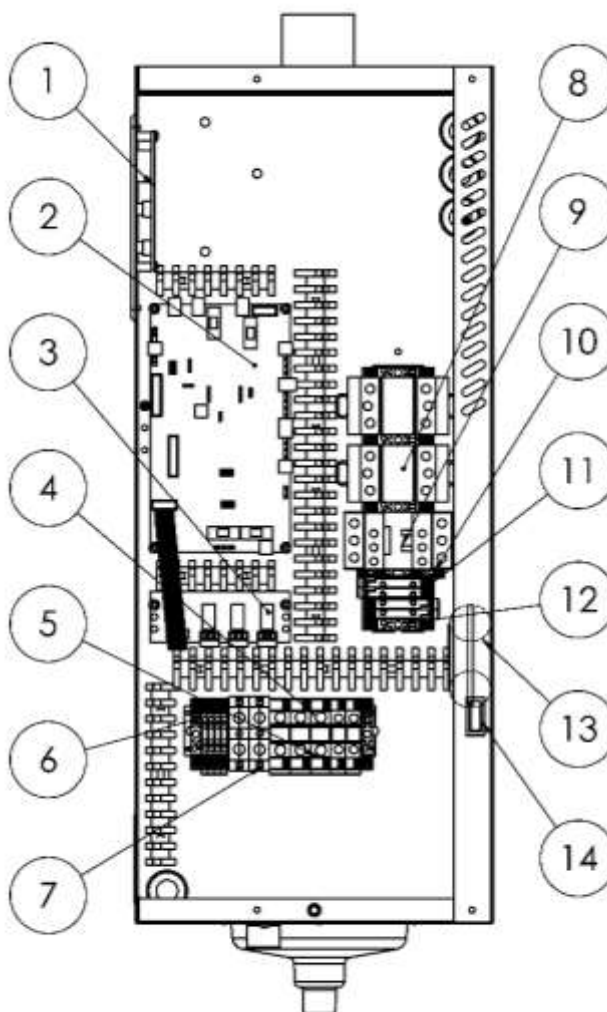

Fig. 7-5. Humidifier electrical compartment



185, Boulevard des Frères Rousseau
76550 Offranville – France
www.devatec.com

Export → Tel. +33 (0)2 35 83 06 44
Email : export@devatec.com

France → Tel. +33 (0)2 35 04 61 41
Email : france@devatec.com

Devatec continues to develop its products. For this reason, product features and specifications may change without notice.

This is a translated version of the original version.

RTH-LC – 11/21 Edition - V 3.0.X program version