



FT-4000 Series Float and Thermostatic Steam Trap

All Stainless Steel

For Pressures to 465 psig (32 bar)... Capacities to 1,080 lb/hr (490 kg/hr)

Steam Trapping and Steam Tracing Equipment

Description

With the FT-4000 Series, you can install a float and thermostatic trap in any piping configuration with little or no repiping. You get the reliability of the float and thermostatic operating principle, plus all the benefits of all-stainless steel construction.

- A sealed, tamperproof package
- A compact, lightweight trap
- Exceptional corrosion resistance
- A one-year guarantee against defective materials and workmanship

FT-4000 Series Float & Thermostatic steam traps combine savings in three important areas: energy, installation and replacement. Mounting the FT-4000 on universal connectors with integral strainers provides quick, easy in-line replacement with added protection from dirt and scale.

Maximum Operating Conditions

Maximum allowable pressure (vessel design):
485 psig @ 600°F (33 bar @ 315°C)

Maximum operating pressure:

Model FT-4075:	75 psig (5 bar) saturated steam
Model FT-4150:	150 psig (10 bar) saturated steam
Model FT-4225:	225 psig (16 bar) saturated steam
Model FT-4300:	300 psig (21 bar) saturated steam
Model FT-4465:	465 psig (32 bar) saturated steam

Materials

Body:	ASTM A240 Grade 304L
Internals:	All stainless steel—304
Valve and seat:	Stainless steel
Thermostatic air vent:	Wafer type-stainless steel with Hastelloy element
Flange	ASTM A105 Zinc plated

Specification

Steam trap shall be float and thermostatic type having stainless steel construction, stainless steel valve, seat and float, for use on an IS-2 connector with integral strainer or TVS 4000 trap valve station. Integral thermostatic element shall be wafer type constructed of Hastelloy and stainless steel. Thermostatic element shall be capable of withstanding 45°F (25°C) of superheat and be resistant to water hammer damage.

How to order

- Specify model number
- Select 360° connector style (IS-2 or TVS 4000)
- Specify maximum working pressure that will be encountered or orifice size
- Specify any options required

For a fully detailed certified drawing, refer to CD #1298 and CD #1299.



TVS 4000 Trap Valve Station With FT-4000 Float and Thermostatic Trap



IS-2 Connector With FT-4000 Float and Thermostatic Trap

Model FT-4000 Series Capacity

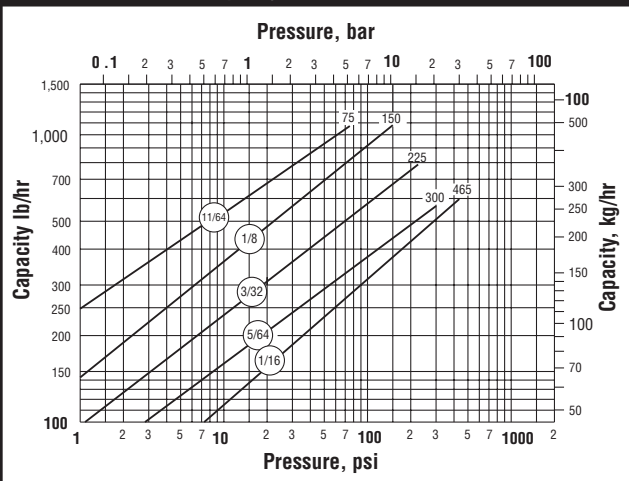

Designs, materials, weights and performance ratings are approximate and subject to change without notice. Visit armstronginternational.com for up-to-date information.

FT-4000 Series Float and Thermostatic Steam Trap

All Stainless Steel

For Pressures to 465 psig (32 bar)... Capacities to 1,080 lb/hr (490 kg/hr)



Steam Trapping and
Steam Tracing Equipment

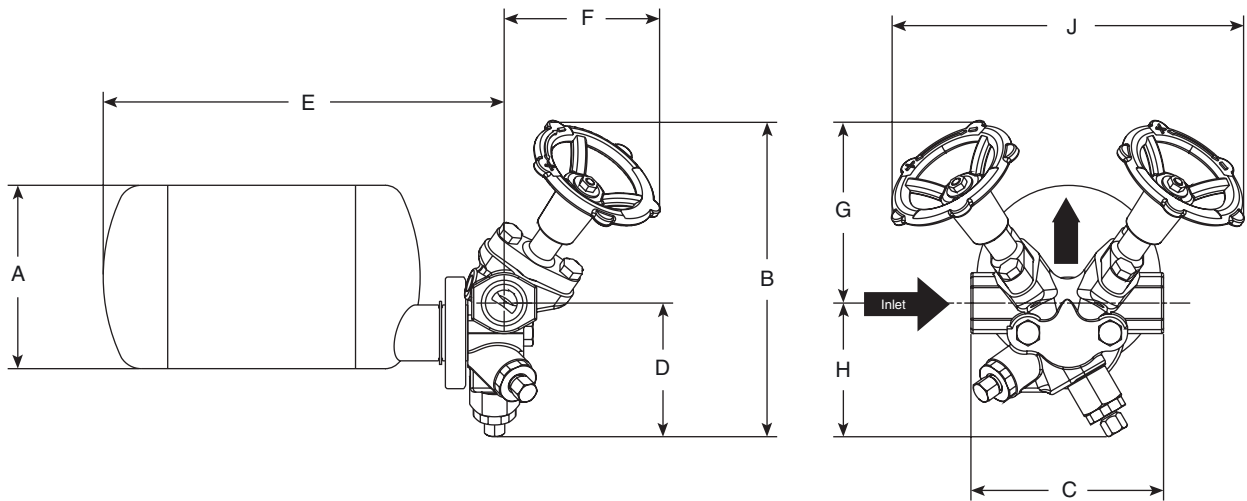

Series FT-4000 With TVS 4000 Trap Valve Station

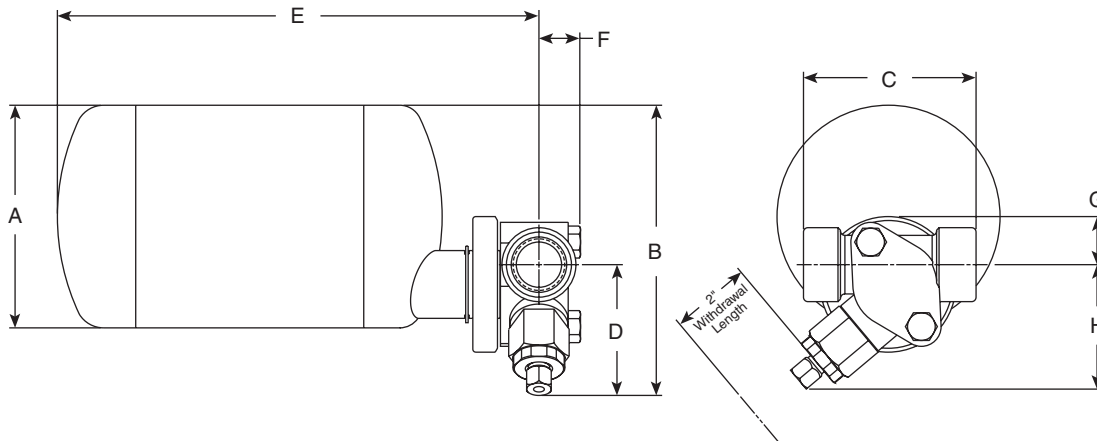

Series FT-4000 With IS-2 Connector With Integral Strainer and Optional Blowdown Valve

FT-4000 Series Float and Thermostatic Steam Trap						
Trap Series	FT-4000					
Model	IS-2 Connector With Integral Strainer				TVS 4000 Connector	
	in	mm	in	mm	in	mm
Pipe Connections	1/2, 3/4	15, 20	1	25	1/2, 3/4	15, 20
"A" Trap Diameter	4-1/2	114	4-1/2	114	4-1/2	114
"B" Total Height	5-7/8	149	5-7/8	149	7-7/8	198
"C" Face-to-Face	3-1/2	89	4	101	4-3/4	120
"D" Connection \varnothing to Bottom	2-5/8	67	2-5/8	67	3-1/4	83
"E" Connection \varnothing to Outside of Trap	10	255	10-1/4	259	9-7/8	250
"F" Connection \varnothing to Front of Connector	7/8	22	7/8	22	3-7/8	98
"G" Connection \varnothing to Top	1	25	1	25	4-1/2	114
"H" Connection \varnothing to Bottom of Connector	2-1/2	64	2-1/2	64	3-1/4	83
"J" Width across Handwheels (valve open)	N/A				8-11/16	221
Test Port Connection	N/A				1/4 NPT	6
Maximum Operating Pressure (saturated steam)	465 psi (32 bar)					
Maximum Allowable Pressure (vessel design)	485 psi @ 600°F (33 bar @ 315°C)					
Trap Only Weight, lb (kg)	6-1/4 (2.8)					
Trap and Connector Weight, lb (kg)	8-3/4 (4)			12-3/4 (5.8)		

Designs, materials, weights and performance ratings are approximate and subject to change without notice. Visit armstronginternational.com for up-to-date information.