

# ICS Series Float & Thermostatic Steam Traps

## Carbon Steel for Horizontal Installation, With Thermostatic Air Vent

For Pressures to 465 psig (32.0 barg) Capacities to 60 000 lb/hr (27 215 kg/hr)



Steam Trapping and Steam Tracing Equipment

### Description

Armstrong ICS Series F&T traps are designed for industrial service upto 465 psig (32.0 barg). The simple yet rugged construction of the ICS series carbon steel float and thermostatic trap is designed to assure long, trouble-free service.

### Materials

Body & Cap:	Carbon Steel ASTM A352 GR.LCB
Internals:	Stainless steel
Valve(s) and Seat(s):	Hardened Stainless Steel, 17-4PH
Thermostatic Air Vent:	Hastelloy Wafer
Bolting:	Low Alloy Steel, ASTM A193 GR.b7
Gasket:	Graphite

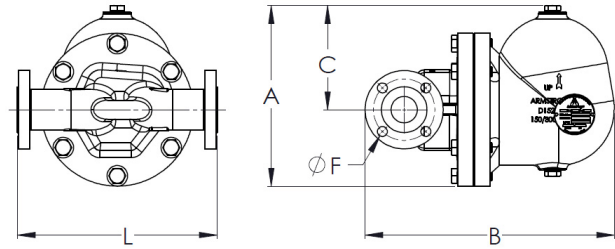

### Connections

Flanged:	ASME B16.5 Class 150, Class 300
Screwed:	NPT BSPT
Socket Welded	

### Option

Integral Vacuum Breaker: Add suffix VB to model number (limited to 150 psig (10.3 barg)).  
Liquid Drainer: Add suffix LD to model number



Flow			
	in	mm	Flow Direction
Horizontal	1/2, 3/4, 1	DN15, DN20, DN25	Left-to-Right
Horizontal	1-1/2, 2	DN40, DN50	Right-to-Left

### Face-to-Face Dimensions - Screwed and Socketweld

Pipe Connections	in	mm	in	mm	in	mm	in	mm	in	mm
	1/2	DN15	3/4	DN20	1	DN25	1-1/2	DN40	2	DN50
"A" Height	8.9	225	8.9	225	9.3	236	11.5	291	11.5	291
"B" Length	11.0	278	11.0	279	12.2	309	14.7	374	14.9	380
"C" Cap $\bar{C}$ to Top	5.4	138	5.4	138	5.6	143	6.9	176	6.9	176
"L" Face-to-Face	7.2	184	7.0	178	7.4	188	10.5	266	10.8	273
Weight lb (kg)	21 (9.5)		21 (9.5)		28 (12.7)		76 (34.5)		76 (34.5)	
Maximum Allowable Pressure (Vessel Design)	580 psig @ 650°F (40.0 barg @ 343°C)									
Maximum Operating Pressure	465 psig (32.0 barg)									

### Face-to-Face Dimensions - ASME B16.5 Class 150#

Pipe Connections	in	mm	in	mm	in	mm	in	mm	in	mm
	1/2	DN15	3/4	DN20	1	DN25	1-1/2	DN40	2	DN50
"A" Height	8.9	225	8.9	225	9.3	236	11.5	291	11.5	291
"B" Length	11.9	301	12.0	305	13.4	339	15.7	399	16.2	412
"C" Cap $\bar{C}$ to Top	5.4	138	5.4	138	5.6	143	6.9	176	6.9	176
"F" Bolt Hole Size	1/2" - 13 UNC		1/2" - 13 UNC		0.63	15.9	0.63	15.9	0.75	19.1
Number of Flange Holes	4									
"L" Face-to-Face	8.0	203	8.1	205	8.2	208	12.6	320	12.3	312
Weight lb (kg)	23 (10.4)		25 (11.3)		33 (14.9)		83 (37.7)		84 (38.1)	
Maximum Allowable Pressure (Vessel Design)	200 psig @ 400°F (13.8 barg @ 204°C)									
Maximum Operating Pressure	200 psig (13.8 barg)									

### Face-to-Face Dimensions - ASME B16.5 Class 300#

Pipe Connections	in	mm	in	mm	in	mm	in	mm	in	mm
	1/2	DN15	3/4	DN20	1	DN25	1-1/2	DN40	2	DN50
"A" Height	8.9	225	8.9	225	9.3	236	11.5	291	11.5	291
"B" Length	11.9	304	12.4	314	13.7	347	16.3	414	16.5	418
"C" Cap $\bar{C}$ to Top	5.4	138	5.4	138	5.6	143	6.9	176	6.9	176
"F" Bolt Hole Size	1/2" - 13 UNC		0.75	19.1	0.75	19.1	0.87	22.2	0.75	19.1
Number of Flange Holes	4								8	
"L" Face-to-Face	8.2	209	8.2	209	8.4	212	12.9	327	12.6	320
Weight lb (kg)	24 (10.8)		26 (11.8)		35 (15.9)		88 (39.9)		88 (39.9)	
Maximum Allowable Pressure (Vessel Design)	580 psig @ 500°F (40.0 barg @ 260°C)									
Maximum Operating Pressure	465 psig (32.0 barg)									

Designs, materials, weights and performance ratings are approximate and subject to change without notice. Visit [armstronginternational.com](http://armstronginternational.com) for up-to-date information.

# ICS Series Float & Thermostatic Steam Traps

## Carbon Steel for Horizontal Installation, With Thermostatic Air Vent

For Pressures to 465 psig (32.0 barg) Capacities to 60 000 lb/hr (27 215 kg/hr)



Steam Trapping and Steam Tracing Equipment

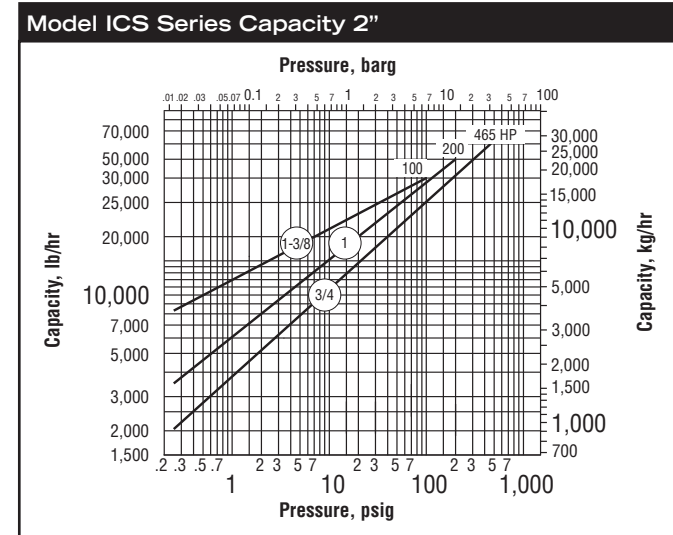
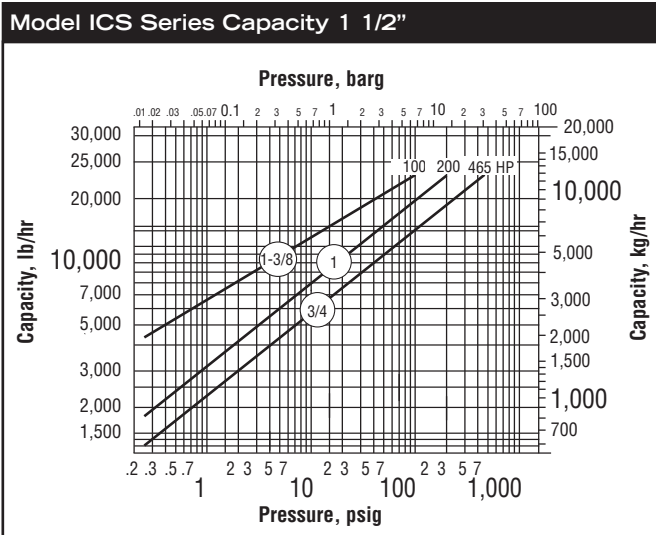
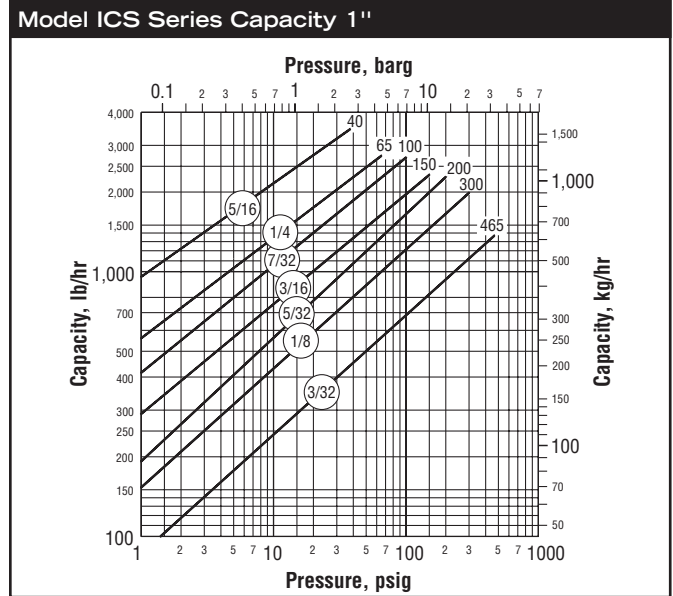
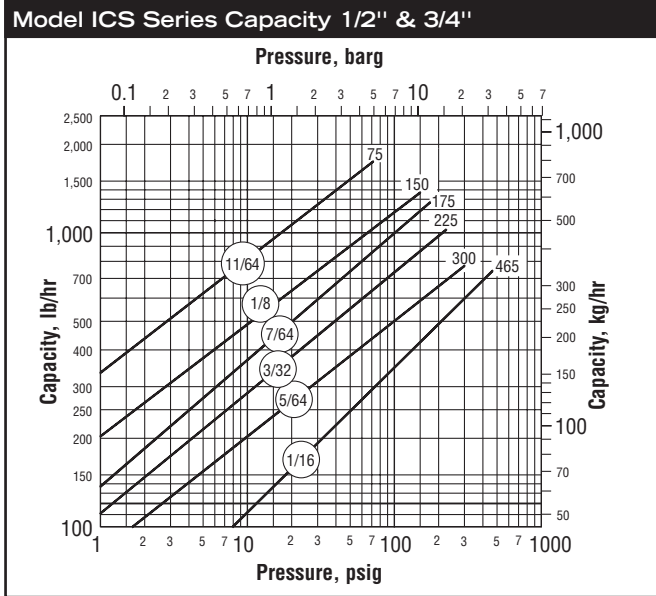

Pressure	Model	Connection Size	Flow Direction	Connection Type
300	ICS	8	R**	SCREWED
(*)	ICS	2 = 1/2" 3 = 3/4" 4 = 1"  6 = 1-1/2" 8 = 2"	L = Left to Right  R = Right to Left	SCREWED SW 150RF 300RF

(\*) Refer to capacity charts to determine orifice.

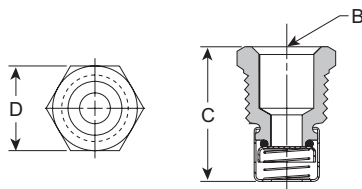

### Options

#### Vacuum Breaker 1/2" NPT (DN15)

Many times, condensate will be retained ahead of steam traps because of the presence of a vacuum. To break a vacuum, air must be introduced into the system by means of a vacuum breaker.

For maximum protection against freezing and water hammer in condensing equipment under modulated control, vacuum breakers are recommended. Armstrong ICS Series F&T Traps are available with integral vacuum breakers. Maximum service pressure is 150 psig (10.3 barg).

Vacuum Breaker			
Size	in	mm	Max. allow. pres.
	1/2 NPT	DN15	
"B" Pipe Connections	3/8 NPT	DN10	150 psig (10.3 barg)
"C" Height	1-1/4	32	
"D" Width	7/8 Hex	22 Hex	

**CAUTION:** Do not use a conventional vacuum breaker open to the atmosphere in any system that incorporates a mechanical return system that carries pressure less than atmospheric pressure. This includes all return systems designated as vacuum returns, variable vacuum returns or subatmospheric returns. If a vacuum breaker must be installed in such a system, it should be of the type that is loaded to open only when the vacuum reaches a calibrated level well in excess of the design characteristics of the system.

# ICS Series Float & Thermostatic Steam Traps

## Carbon Steel for Vertical Installation, With Thermostatic Air Vent

For Pressures to 465 psig (32.0 barg) Capacities to 60 000 lb/hr (27 215 kg/hr)



Steam Trapping and Steam Tracing Equipment

### Description

Armstrong ICS Series F&T traps are designed for industrial service upto 465 psig (32.0 barg). The simple yet rugged construction of the ICS series carbon steel float and thermostatic trap is designed to assure long, trouble-free service.

### Materials

Body & Cap:	Carbon Steel ASTM A352 GR.LCB
Internals:	Stainless steel
Valve(s) and Seat(s):	Hardened Stainless Steel, 17-4PH
Thermostatic Air Vent:	Hastelloy Wafer
Bolting:	Low Alloy Steel, ASTM A193 GR.b7
Gasket:	Graphite

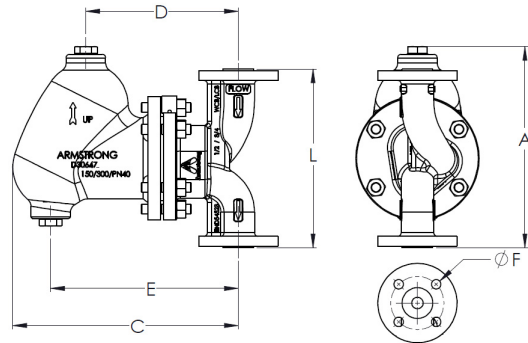

### Connections

Flanged:	ASME B16.5, Class 150, Class 300
Screwed:	NPT BSPT
Socket Welded	

### Option

Integral Vacuum Breaker: Add suffix VB to model number (limited to 150 psig (10.3 barg)).  
Liquid Drainer: Add suffix LD to model number



### Flow Direction

Vertical: Top to Bottom

**Dimensions Table - Screwed and Socketweld**

Pipe Connection	in	mm	in	mm	in	mm	in	mm	in	mm
	1/2	DN15	3/4	DN20	1	DN25	1-1/2	DN40	2	DN50
"A" Height	8.5	216	8.5	216	9.0	228	12.6	319	12.6	319
"C" Length	10.9	279	10.9	279	12.2	309	14.9	380	14.9	380
"D" Length Cap $\varnothing$ to Body $\varnothing$ (Vent)	6.8	173	6.8	173	7.6	193	9.4	238	9.4	238
"E" Length Cap $\varnothing$ to Body $\varnothing$ (Drain)	8.4	213	8.4	213	8.9	228	9.4	238	9.4	238
"L" Face-to-Face	7.0	178	7.0	178	7.4	188	12.0	306	12.0	305
Weight lb (kg)	23 lb (10.4 kg)		23 lb (10.4 kg)		31 lb (14.1 kg)		85 lb (38.6 kg)		85 lb (38.6 kg)	
Maximum Allowable Pressure (Vessel Design)	580 psig @ 650°F (40.0 barg @ 343°C)									
Maximum Operating Pressure	465 psig (32.0 barg)									

**Dimensions Table - ASME B16.5 Class 150**

Pipe Connections	in	mm	in	mm	in	mm	in	mm	in	mm
	1/2	DN15	3/4	DN20	1	DN25	1-1/2	DN40	2	DN50
"A" Height	8.9	228	9.0	229	9.4	238	12.6	321	12.6	321
"C" Length	11.9	301	12.0	306	13.4	339	15.7	399	15.7	399
"D" Length Cap $\varnothing$ to Body $\varnothing$ (Vent)	6.8	173	6.8	173	7.6	193	9.4	238	9.4	238
"E" Length Cap $\varnothing$ to Body $\varnothing$ (Drain)	8.4	213	8.4	213	8.9	228	9.4	238	9.4	238
"F" Bolt Hole Size	1/2" - 13 UNC		1/2" - 13 UNC		0.63	16.0	1/2" - 13 UNC		0.75	19.1
Number of Flange Holes	4									
"L" Face-to-Face	7.9	203	8.1	205	8.2	208	12.2	309	12.2	309
Weight lb (kg)	26 lb (11.7 kg)		27 lb (12.2 kg)		36 lb (16.3 kg)		94 lb (42.6 kg)		94 lb (42.6 kg)	
Maximum Allowable Pressure (Vessel Design)	200 psig @ 400°F (13.6 barg @ 205°C)									
Maximum Operating Pressure	200 psig (14.0 barg)									

**Dimensions Table - ASME B16.5 Class 300**

Pipe Connections	in	mm	in	mm	in	mm	in	mm	in	mm
	1/2	DN15	3/4	DN20	1	DN25	1-1/2	DN40	2	DN50
"A" Height	9.1	231	9.1	231	9.5	241	12.8	324	12.8	324
"C" Length	11.9	304	12.4	314	13.7	347	16.3	414	16.5	419
"D" Length Cap $\varnothing$ to Body $\varnothing$ (Vent)	6.8	173	6.8	173	7.6	193	9.4	238	9.4	238
"E" Length Cap $\varnothing$ to Body $\varnothing$ (Drain)	8.4	213	8.4	213	8.9	228	9.4	238	9.4	238
"F" Bolt Hole Size	1/2" - 13 UNC		0.75	19.1	0.75	19.1	0.87	22.2	0.75	19.1
Number of Flange Holes	4					8				
"L" Face-to-Face	8.2	209	8.2	209	8.4	212	12.4	315	12.4	315
Weight lb (kg)	26 lb (11.7 kg)		27 lb (12.2 kg)		36 lb (16.3 kg)		94 lb (42.6 kg)		94 lb (42.6 kg)	
Maximum Allowable Pressure (Vessel Design)	580 psig @ 500°F (40.0 barg @ 260°C)									
Maximum Operating Pressure	465 psig (32.0 barg)									

Designs, materials, weights and performance ratings are approximate and subject to change without notice. Visit [armstronginternational.com](http://armstronginternational.com) for up-to-date information.

# ICS Series Float & Thermostatic Steam Traps

## Carbon Steel for Vertical Installation, With Thermostatic Air Vent

For Pressures to 465 psig (32.0 barg) Capacities to 60 000 lb/hr (27 215 kg/hr)



Steam Trapping and Steam Tracing Equipment

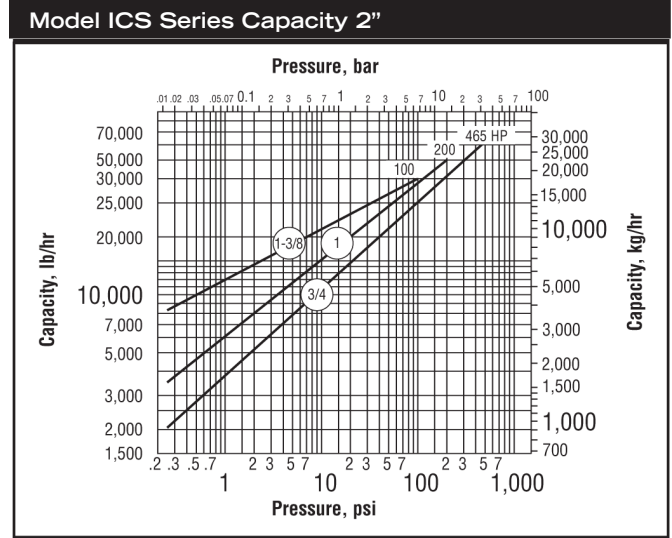
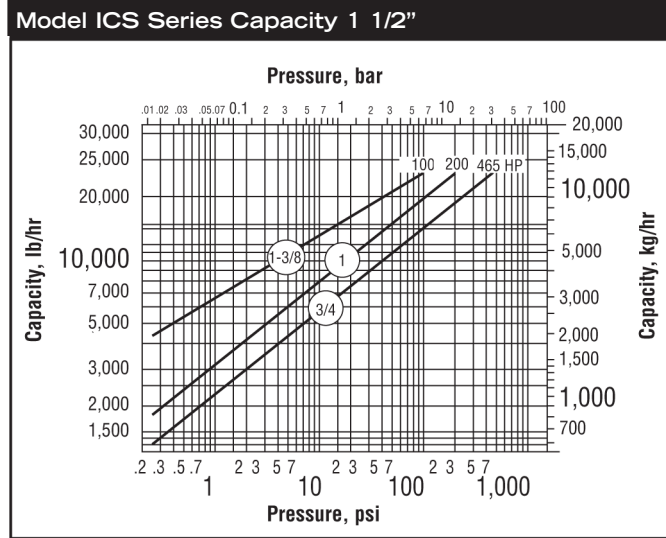
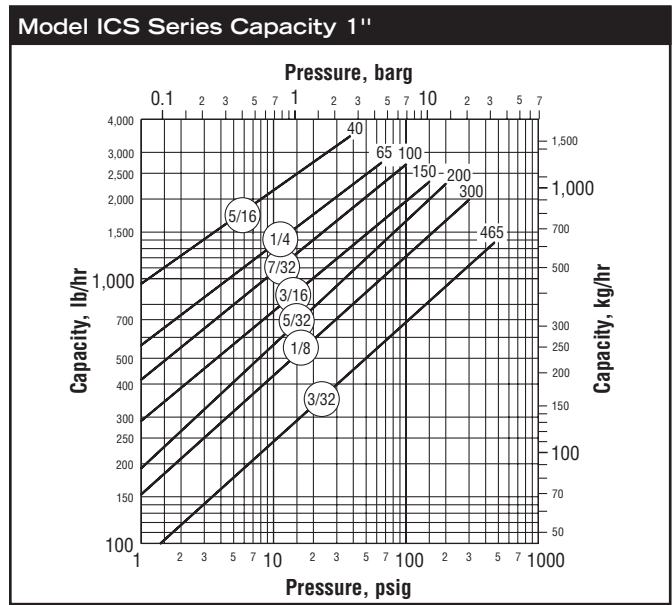
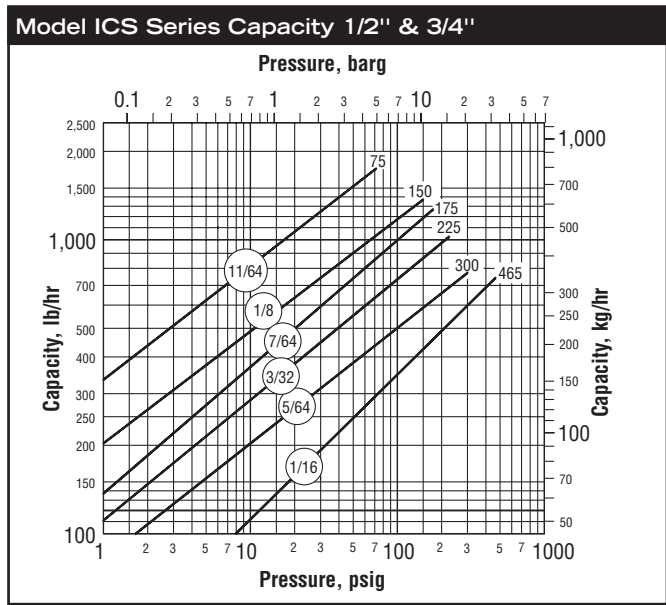

Pressure	Model	Connection Size	Flow Direction	Connection Type
300	ICS	8	V	SCREWED
(*)	ICS	2 = 1/2" 3 = 3/4" 4 = 1" <hr/> 6 = 1-1/2" 8 = 2"	Top to Bottom	Screw SW 150RF 300RF

(\*) Refer to capacity charts to determine orifice.

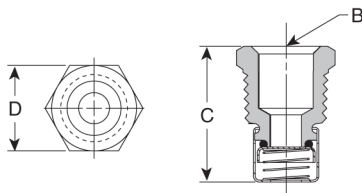

### Options

#### Vacuum Breaker 1/2" NPT (DN15)

Many times, condensate will be retained ahead of steam traps because of the presence of a vacuum. To break a vacuum, air must be introduced into the system by means of a vacuum breaker.

For maximum protection against freezing and water hammer in condensing equipment under modulated control, vacuum breakers are recommended. Armstrong ICS Series F&T Traps are available with integral vacuum breakers. Maximum service pressure is 150 psig (10.3 barg).

Vacuum Breaker			
Size	in	mm	Max. allow. pres.
	1/2 NPT	DN15	
"B" Pipe Connections	3/8 NPT	DN10	150 psig (10.3 barg)
"C" Height	1-1/4	32	
"D" Width	7/8 Hex	22 Hex	

**CAUTION:** Do not use a conventional vacuum breaker open to the atmosphere in any system that incorporates a mechanical return system that carries pressure less than atmospheric pressure. This includes all return systems designated as vacuum returns, variable vacuum returns or subatmospheric returns. If a vacuum breaker must be installed in such a system, it should be of the type that is loaded to open only when the vacuum reaches a calibrated level well in excess of the design characteristics of the system.

Designs, materials, weights and performance ratings are approximate and subject to change without notice. Visit [armstronginternational.com](http://armstronginternational.com) for up-to-date information.