

NOTES:

- TANK MATERIAL: STEEL
- ALL DIMENSIONS ARE ±0.25"
- DRAWING NOT FOR CONSTRUCTION
- CONSULT FACTORY AT TIME OF ORDER FOR CURRENT PRINT
- INLET BASKET STRAINER OR Y-STRAINER ALSO AVAILABLE

CONTROL PANEL OPTIONS ALSO AVAILABLE (NOT SHOWN):

- NEMA 4 OR NEMA 4X OR NEMA 3R CONSTRUCTION
- POWER ON LIGHT
- PUMP TEST BUTTON
- PUMP RUN TIME METER
- EXTRA DRY CONTACTS
- UL/CUL LABELED PANEL
- HIGH LEVEL ALARM HORN & LIGHT W/SILENCE SWITCH

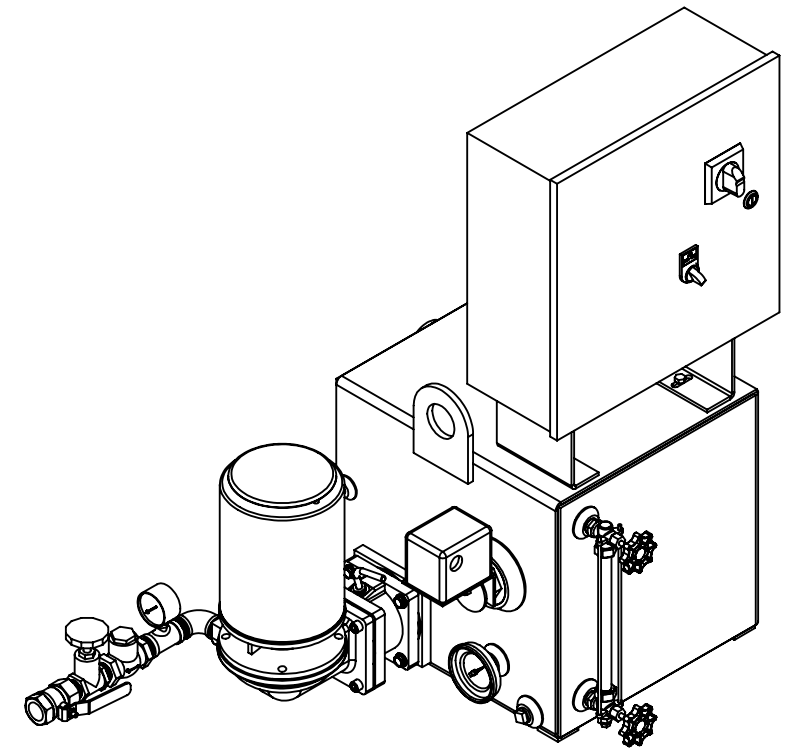
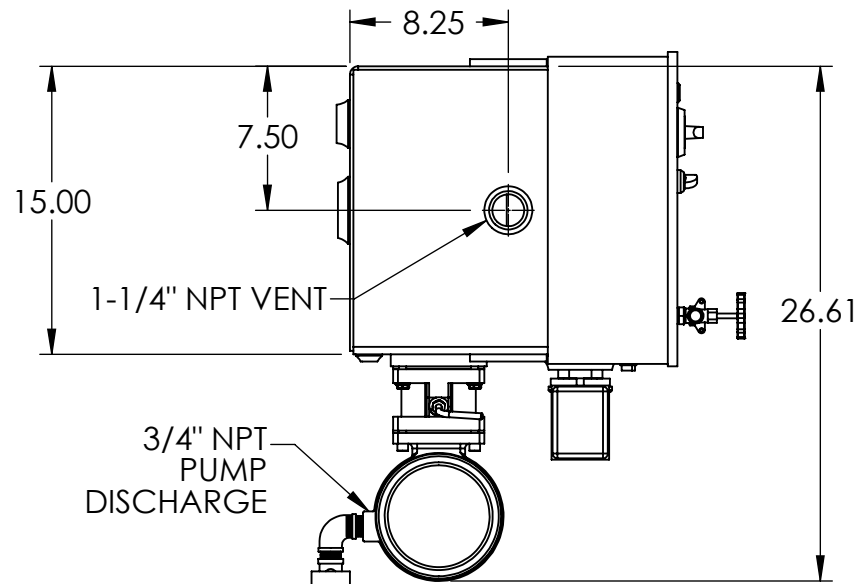

PRESSURE GAUGE, CHECK VALVE
GATE VALVE AND BALL VALVE
(OPTIONAL)

LIFTING EYES
(OPTIONAL)

FLOAT SWITCH

GAUGE GLASS
(OPTIONAL)

THERMOMETER
(OPTIONAL)

NEMA 12
CONTROL PANEL
(OPTIONAL)

ISOLATION VALVE
(OPTIONAL)

2\"/>

1-1/4\"/>

3.91

1/2\"/>

1.00

14.50

16.50

36.44

15.25

13.25

3.00

7.50

.25
FOOT PAD

4.00

19.00

23.97

35.96

REV	DESCRIPTION	ECN	NAME	DATE
A	Initial Design		GJM	3/16/2018

PART NO:	Ref PartNo	NAME	DATE	 THIRD ANGLE PROJECTION TITLE 15 GALLON SIMPLEX 4100 SERIES "G" CONDENSATE PUMP
FABRICATION TOLERANCES UNLESS OTHERWISE SPECIFIED: DIMENSIONS ARE IN INCHES	DRAWN	GJM	3/16/2018	
TOLERANCES: ANGULAR DIMENSIONS ±1° FRACTIONS ±1/32	CHECKED			
TWO PLACE DECIMAL ±0.06 THREE PLACE DECIMAL ±0.030	ENG APPR.			
PRODUCT FAMILY HTSP Boiler and Condensate		PRODUCT CATEGORY		
SHEET: 1 OF 1	WEIGHT 221.16	DRAWING MAY NOT BE PRINTED TO SCALE. SCALE: 1:10	DWG NO. 684.41015.01G	REV A

