

**NOTES:**

- TANK MATERIAL: STEEL
- ALL DIMENSIONS ARE ±0.25"
- DRAWING NOT FOR CONSTRUCTION
- CONSULT FACTORY AT TIME OF ORDER FOR CURRENT PRINT
- INLET BASKET STRAINER OR Y-STRAINER ALSO AVAILABLE

**CONTROL PANEL OPTIONS ALSO AVAILABLE (NOT SHOWN):**

- NEMA 4 OR NEMA 4X OR NEMA 3R CONSTRUCTION
- POWER ON LIGHT
- PUMP TEST BUTTON
- PUMP RUN TIME METER
- EXTRA DRY CONTACTS
- UL/CUL LABELED PANEL
- HIGH LEVEL ALARM HORN & LIGHT W/SILENCE SWITCH

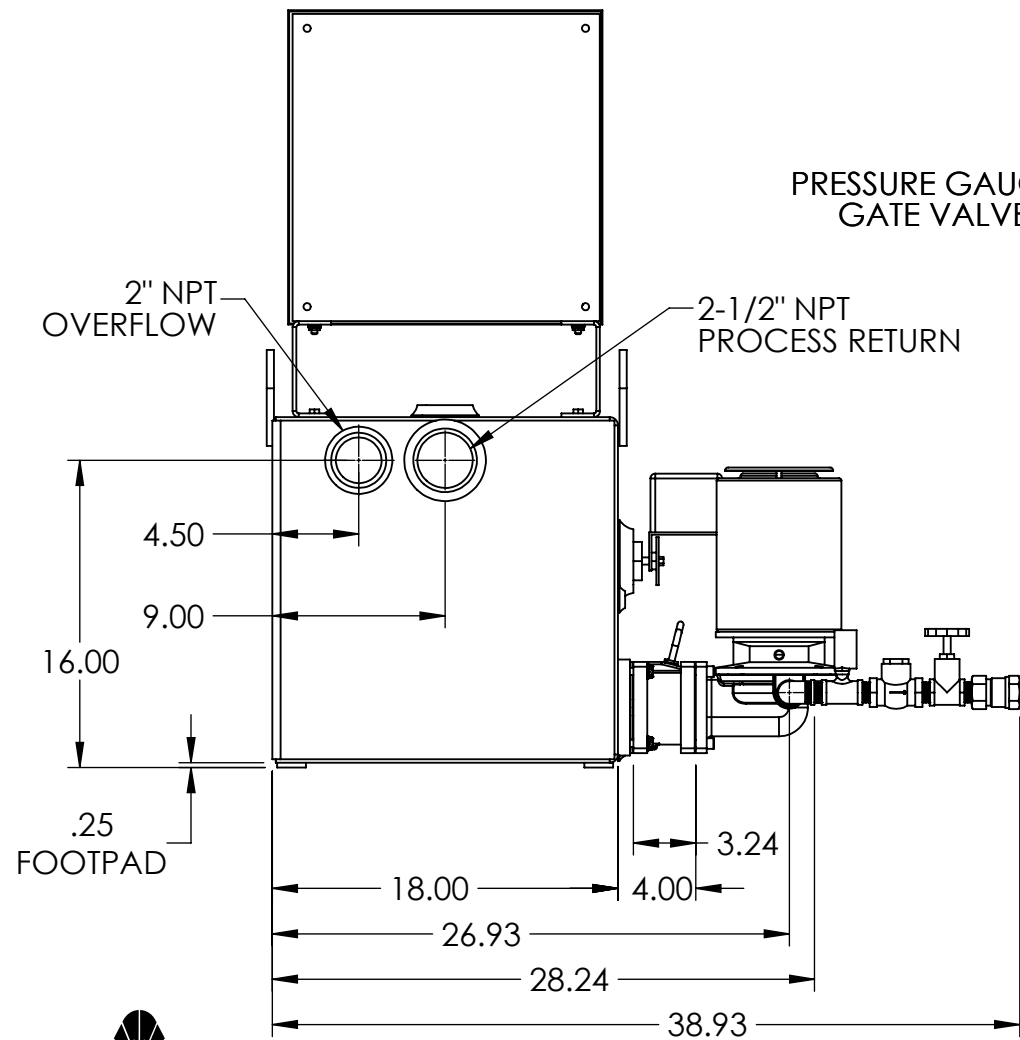
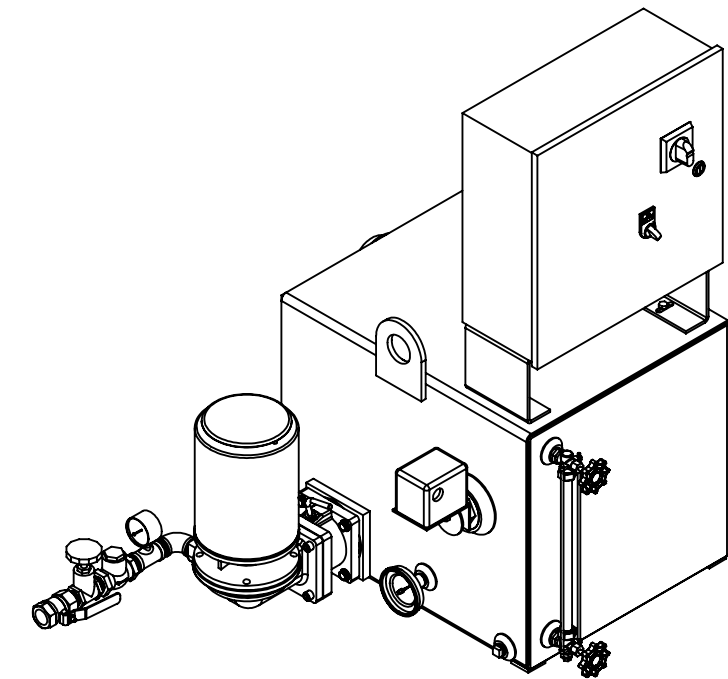
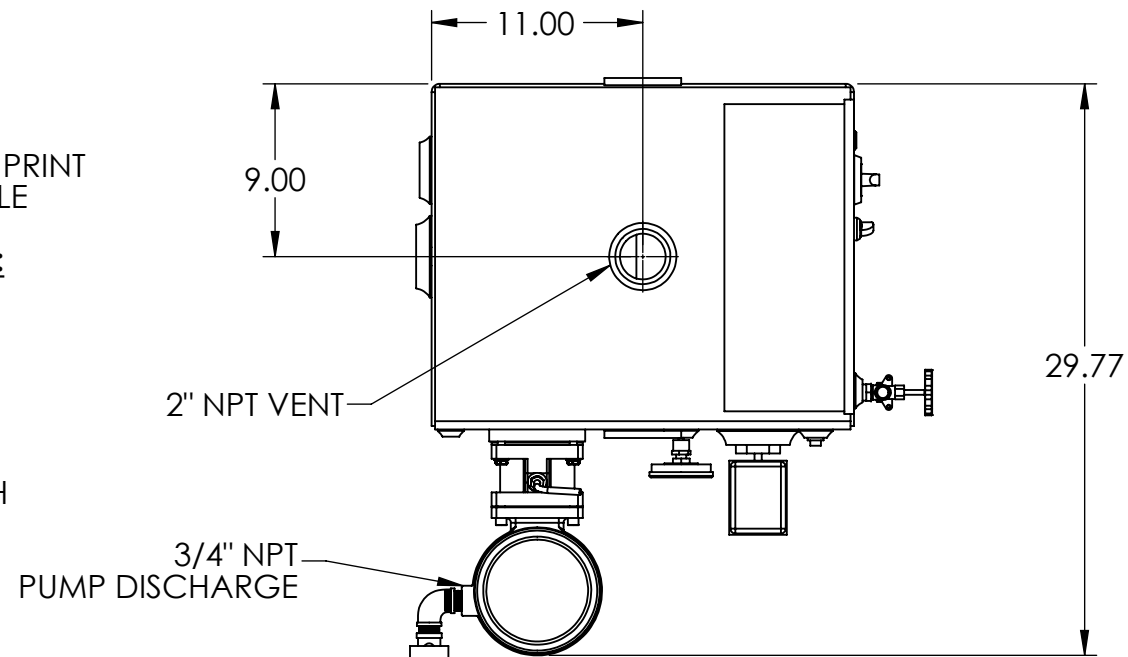

PRESSURE GAUGE, CHECK VALVE  
GATE VALVE AND BALL VALVE  
(OPTIONAL)

LIFTING EYES  
(OPTIONAL)

3.91

.13

20.00

22.00

NEMA 12  
CONTROL PANEL  
(OPTIONAL)

FLOAT SWITCH

GAUGE GLASS  
(OPTIONAL)

THERMOMETER  
(OPTIONAL)

1/2" NPT  
DRAIN

ISOLATION VALVE  
(OPTIONAL)

39.44

18.25

REV	DESCRIPTION	ECN	NAME	DATE
A	INITIAL DESIGN		GJM	3/16/2018

PART NO:	Ref PartNo	NAME	DATE
		GJM	3/16/2018

FABRICATION TOLERANCES UNLESS OTHERWISE SPECIFIED: DIMENSIONS ARE IN INCHES	CHECKED	ENG APPR.	THIRD ANGLE PROJECTION
TOLERANCES: ANGULAR DIMENSIONS ±1° FRACTIONS ±1/32 TWO PLACE DECIMAL ±0.06 THREE PLACE DECIMAL ±0.030			

TITLE	PRODUCT FAMILY	PRODUCT CATEGORY
30 GALLON SIMPLEX 4100 SERIES "G" CONDENSATE PUMP	HTSP Boiler and Condensate	

SHEET: 1 OF 1	WEIGHT	DRAWING MAY NOT BE PRINTED TO SCALE.	DWG NO.	REV
		SCALE: 1:10	684.41030.01G	A

