

NOTES:

- TANK MATERIAL: STEEL
- ALL DIMENSIONS ARE ±0.25"
- DRAWING NOT FOR CONSTRUCTION
- CONSULT FACTORY AT TIME OF ORDER FOR CURRENT PRINT
- INLET Y-STRAINER OR BASKET STRAINER ALSO AVAILABLE

CONTROL PANEL OPTIONS ALSO AVAILABLE (NOT SHOWN):

- NEMA 4 OR NEMA4X OR NEMA3R CONSTRUCTION
- ELECTRIC ALTERNATOR
- POWER ON LIGHT
- PUMP TEST BUTTON
- PUMP RUN TIME METER
- EXTRA DRY CONTACTS
- UL/CUL LABELED PANEL
- HIGH LEVEL ALARM HORN & LIGHT W/SILENCE SWITCH
- LEAD-AUTO-LAG SELECTOR SWITCH

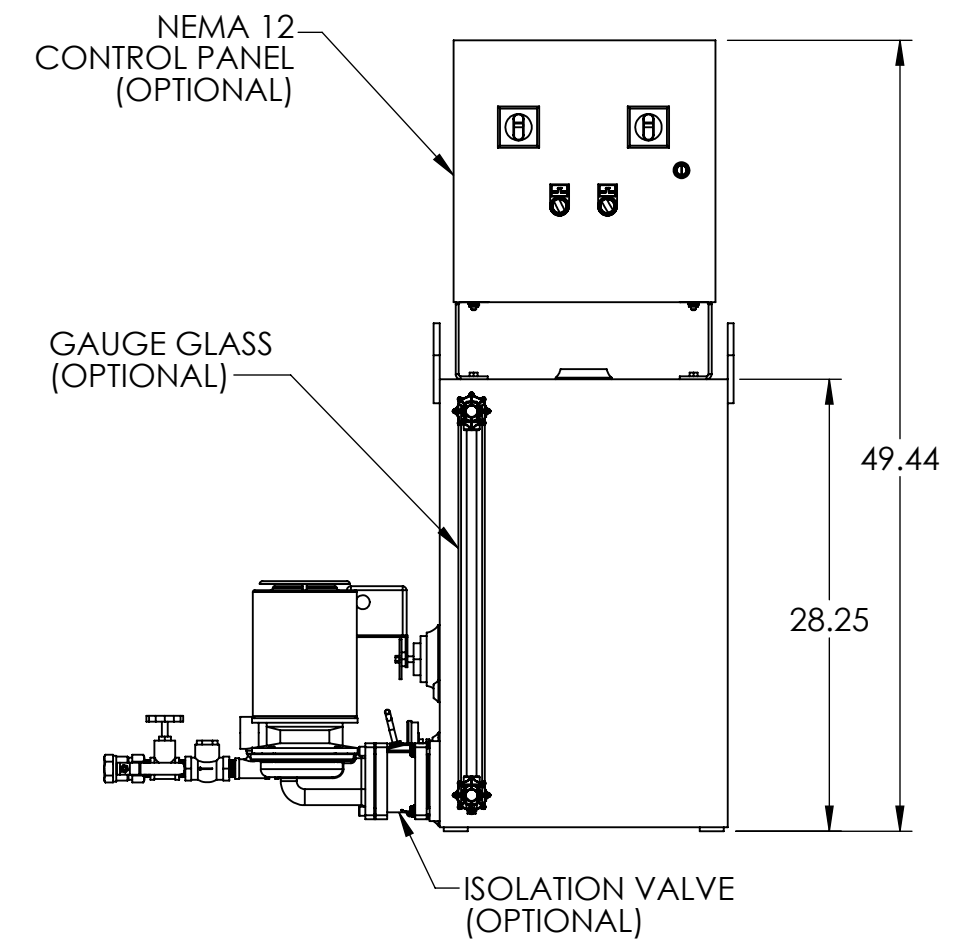
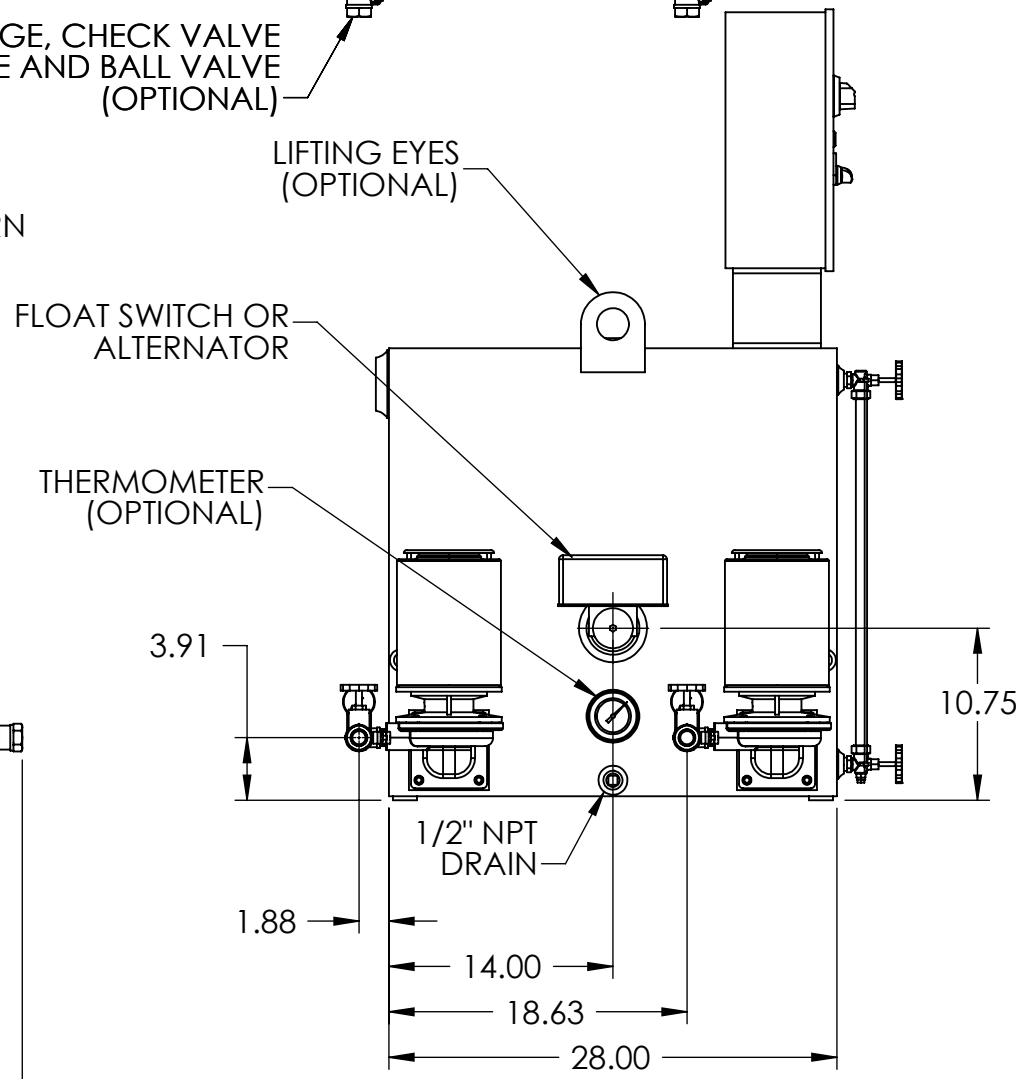
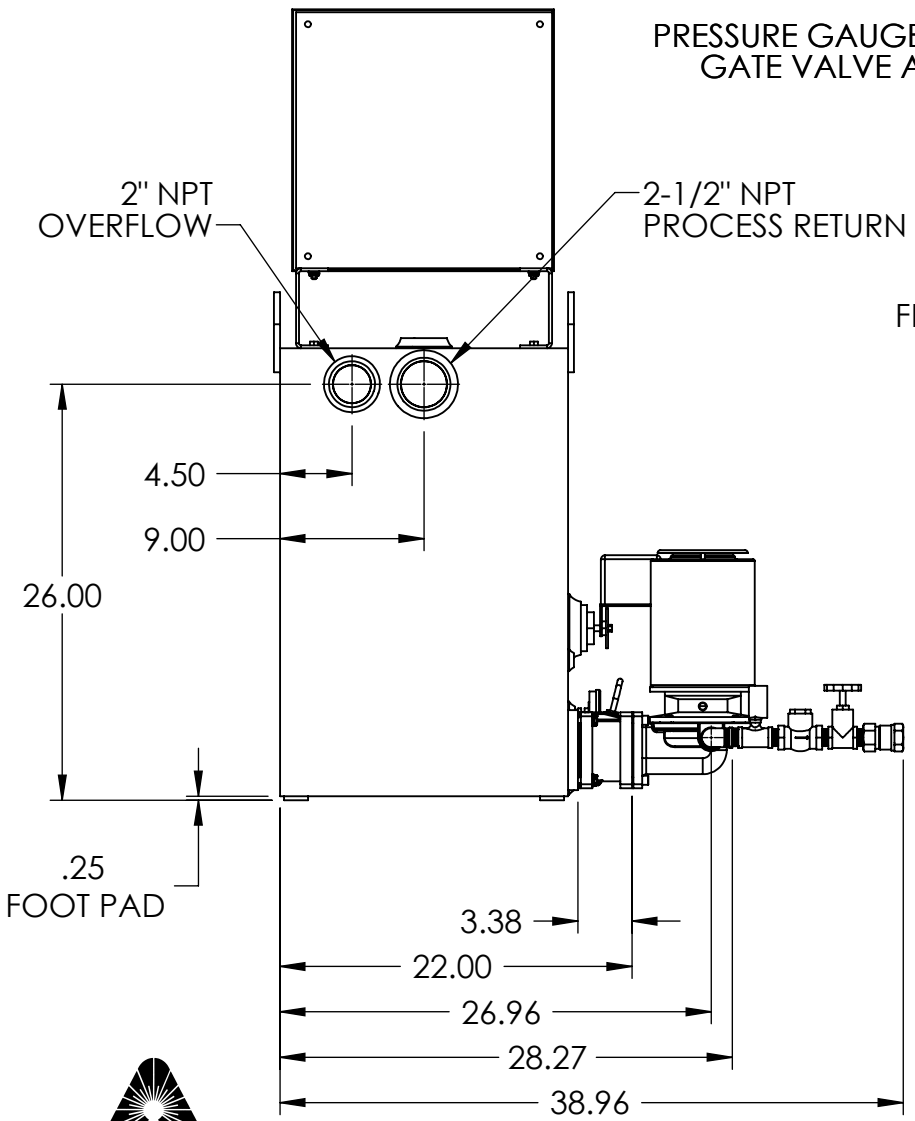
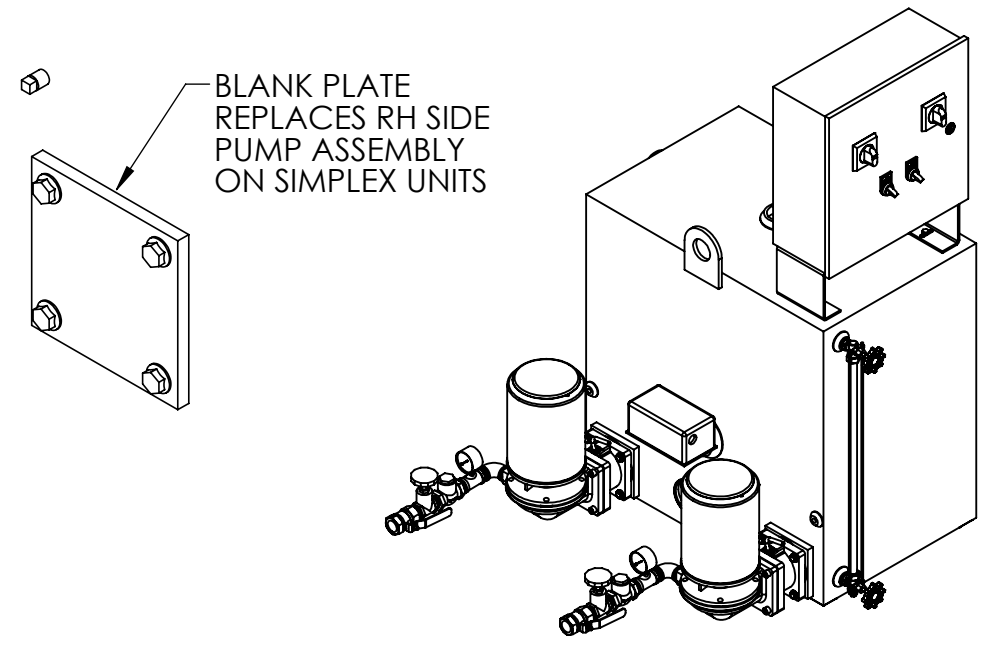
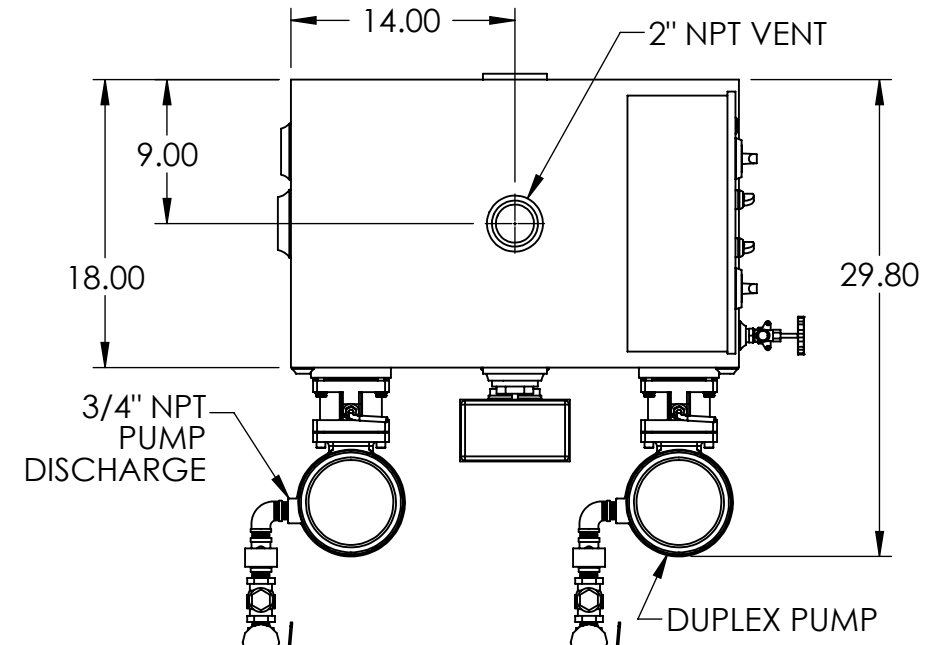

REV	DESCRIPTION	ECN	NAME	DATE
B				
PART NO: Ref PartNo		NAME	DATE	
FABRICATION TOLERANCES UNLESS OTHERWISE SPECIFIED: DIMENSIONS ARE IN INCHES		DRAWN	GJM	3/16/2018
TOLERANCES: ANGULAR DIMENSIONS ±1° FRACTIONS ±1/32		CHECKED		
TWO PLACE DECIMAL ±0.06 THREE PLACE DECIMAL ±0.030		ENG APPR.		
SHEET: 1 OF 1		WEIGHT	445.35	DRAWING MAY NOT BE PRINTED TO SCALE. SCALE: 1:12
		DWG NO.	684.41060.00G	REV B

THIRD ANGLE PROJECTION
**60 GALLON SIMPLEX/DUPLEX
 4100 SERIES
 "G" CONDENSATE PUMP**