

NOTES:

- TANK MATERIAL: STEEL
- ALL DIMENSIONS ARE ±0.25"
- DRAWING NOT FOR CONSTRUCTION
- CONSULT FACTORY AT TIME OF ORDER FOR CURRENT PRINT
- INLET BASKET STRAINER OR Y-STRAINER ALSO AVAILABLE

CONTROL PANEL OPTIONS ALSO AVAILABLE (NOT SHOWN):

- NEMA 4 OR NEMA 4X OR NEMA 3R CONSTRUCTION
- ELECTRIC ALTERNATOR
- POWER ON LIGHT
- PUMP TEST BUTTON
- PUMP RUN TIME METER
- EXTRA DRY CONTACTS
- UL/CUL LABELED PANEL
- HIGH LEVEL ALARM HORN & LIGHT W/SILENCE SWITCH
- LEAD-AUTO-LAG SELECTOR SWITCH

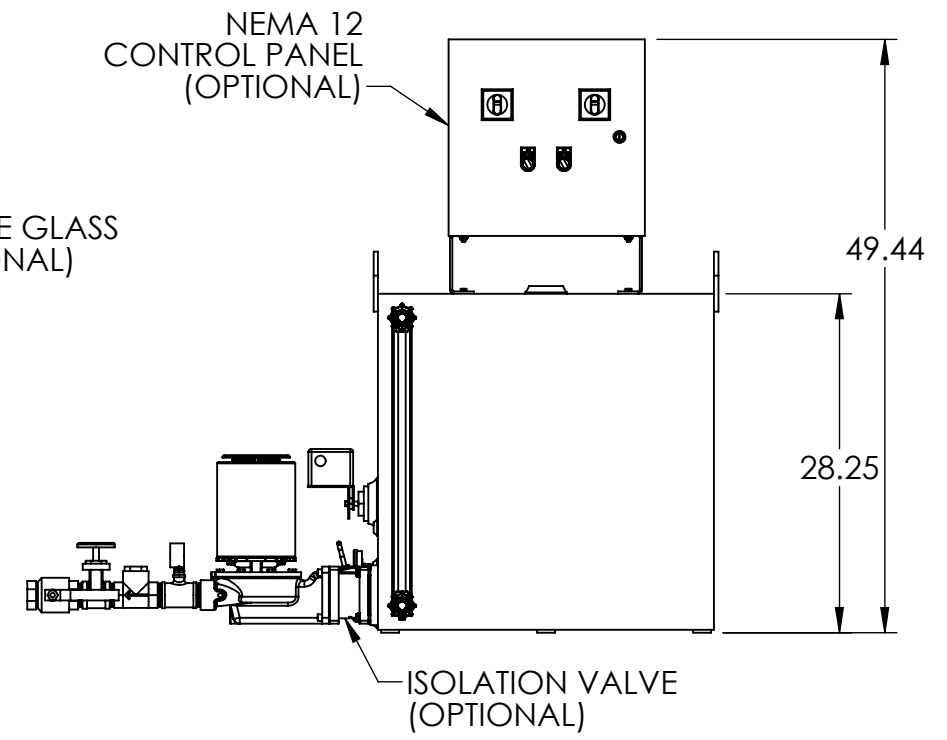
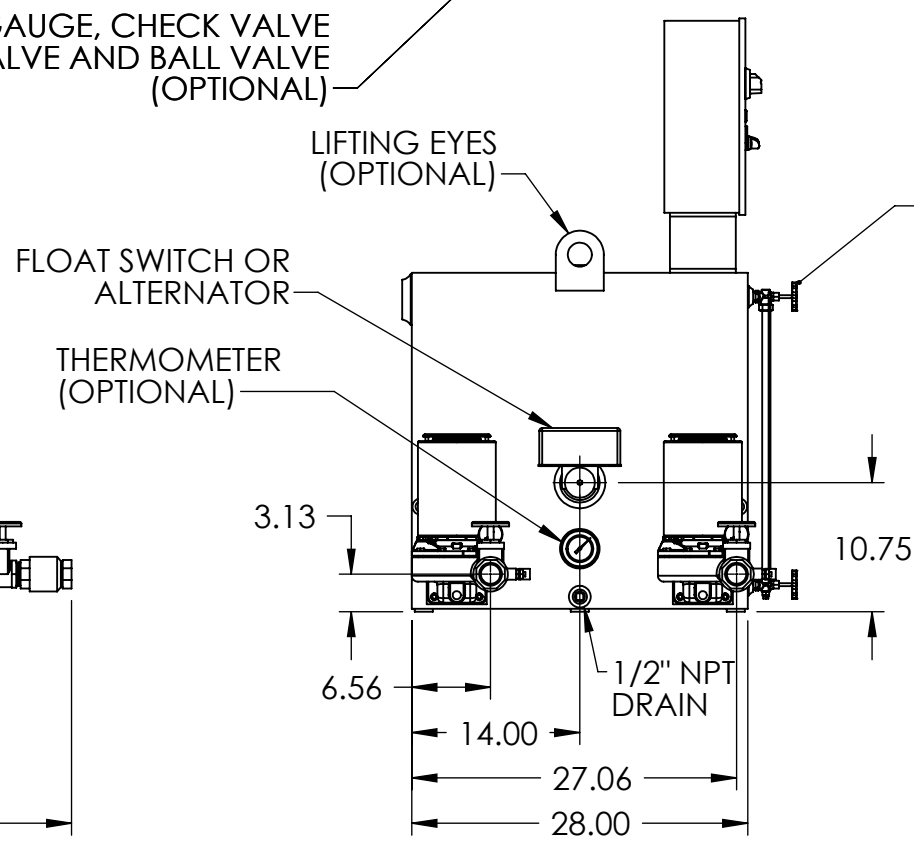
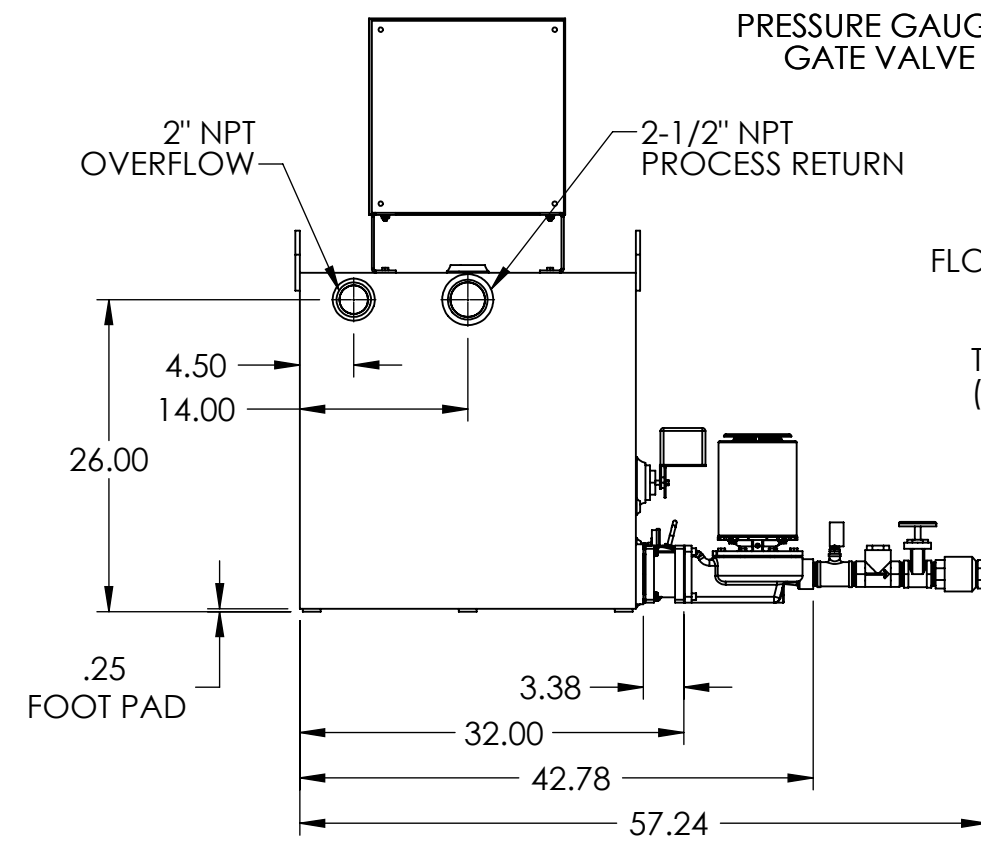
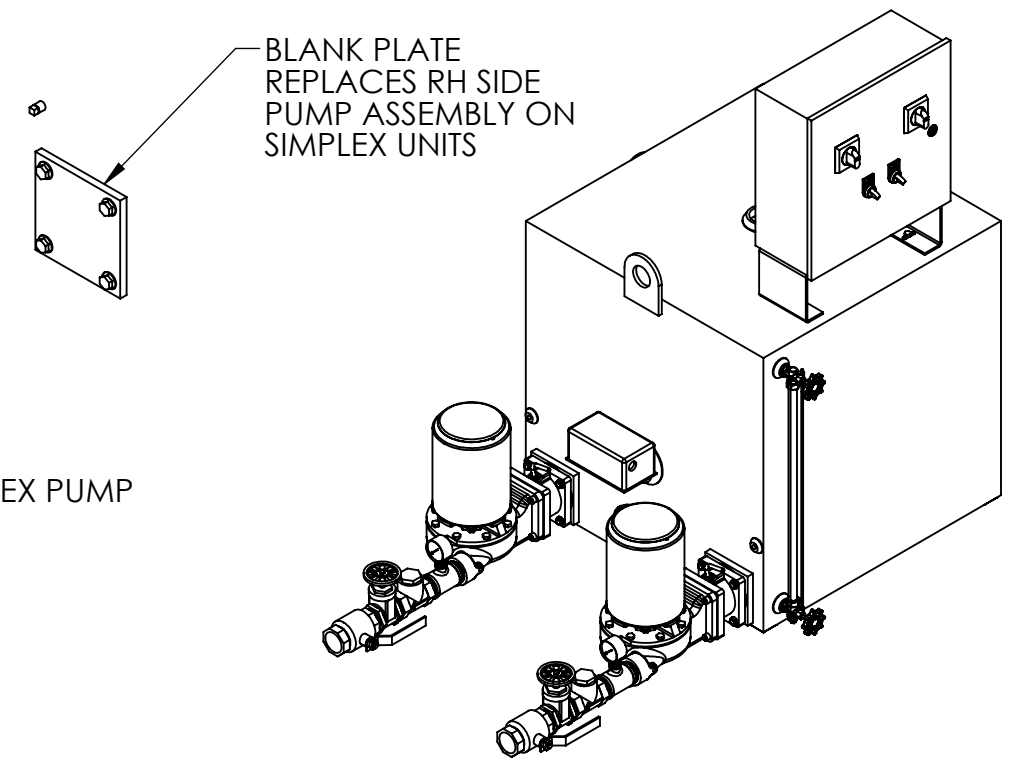
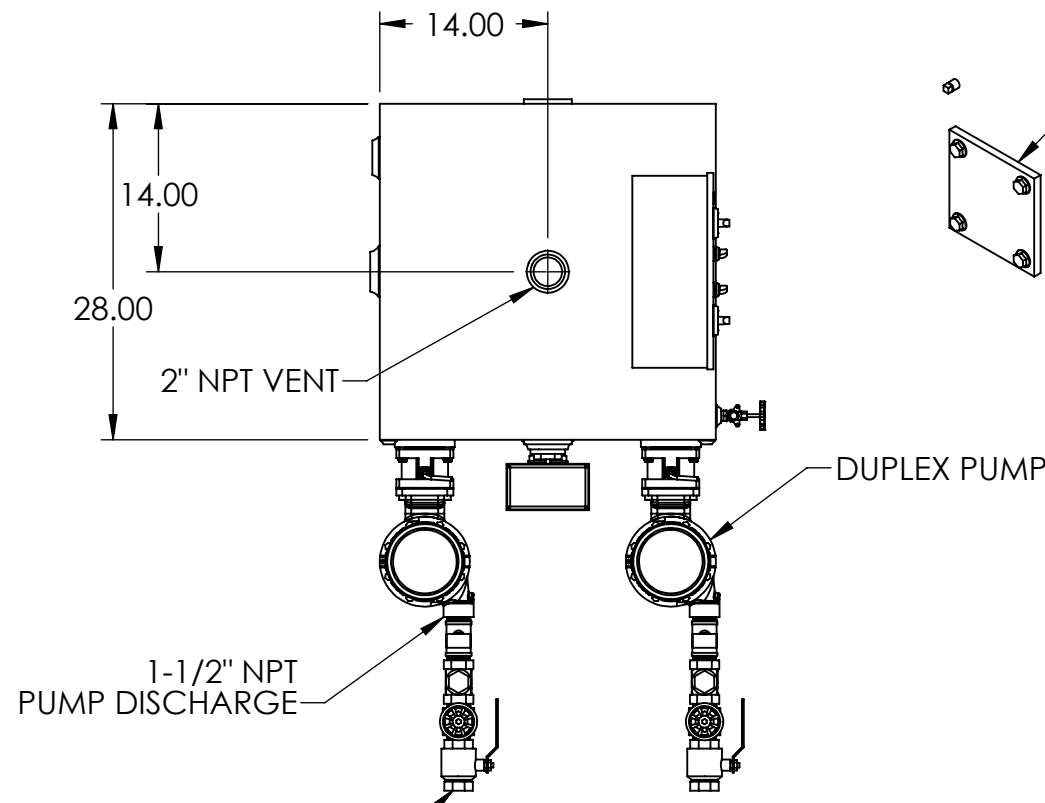

REV	DESCRIPTION	ECN	NAME	DATE
A	Initial Design		GJM	4/12/2018

PART NO:	Ref PartNo	NAME	DATE	 95 GALLON SIMPLEX/DUPLEX 4100 SERIES "J" CONDENSATE PUMP
FABRICATION TOLERANCES UNLESS OTHERWISE SPECIFIED: DIMENSIONS ARE IN INCHES	DRAWN	GJM	4/12/2018	
TOLERANCES: ANGULAR DIMENSIONS ±1° FRACTIONS ±1/32	CHECKED			
TWO PLACE DECIMAL ±0.06 THREE PLACE DECIMAL ±0.030	ENG APPR.			
		PRODUCT FAMILY	HTSP Boiler and Condensate	
		PRODUCT CATEGORY		
SHEET: 1 OF 1	WEIGHT	DRAWING MAY NOT BE PRINTED TO SCALE.	DWG NO.	REV
	585.51	SCALE: 1:16	684.41095.00J	A

