

NOTES:

- TANK MATERIAL: CAST IRON PER ASTM A48 CLASS 30
- ALL DIMENSIONS ARE ±0.25"
- DRAWING NOT FOR CONSTRUCTION
- CONSULT FACTORY AT TIME OF ORDER FOR CURRENT PRINT
- INLET BASKET STRAINER OR Y-STRAINER ALSO AVAILABLE

CONTROL PANEL OPTIONS (NOT SHOWN):

- NEMA 4 OR NEMA 4X OR NEMA 3R CONSTRUCTION
- POWER ON LIGHT
- PUMP TEST BUTTON
- PUMP RUN TIME METER
- EXTRA DRY CONTACTS
- UL/CUL LABELED PANEL
- HIGH LEVEL ALARM HORN & LIGHT W/SILENCE SWITCH

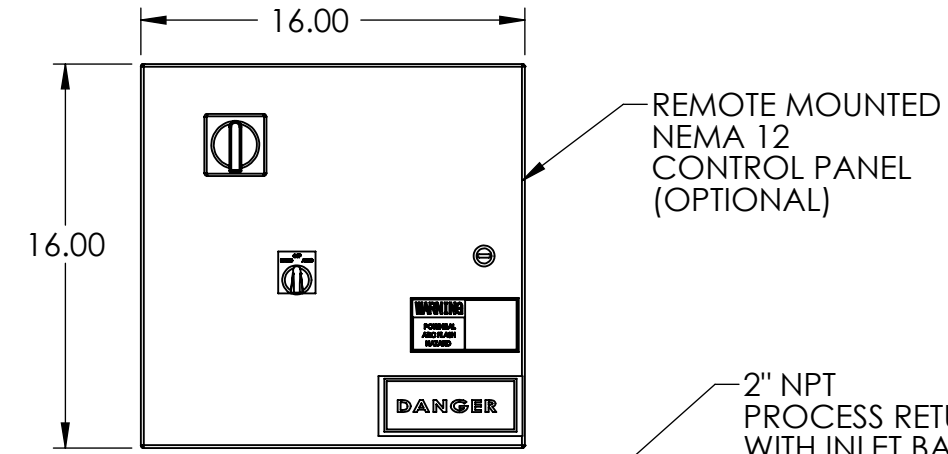
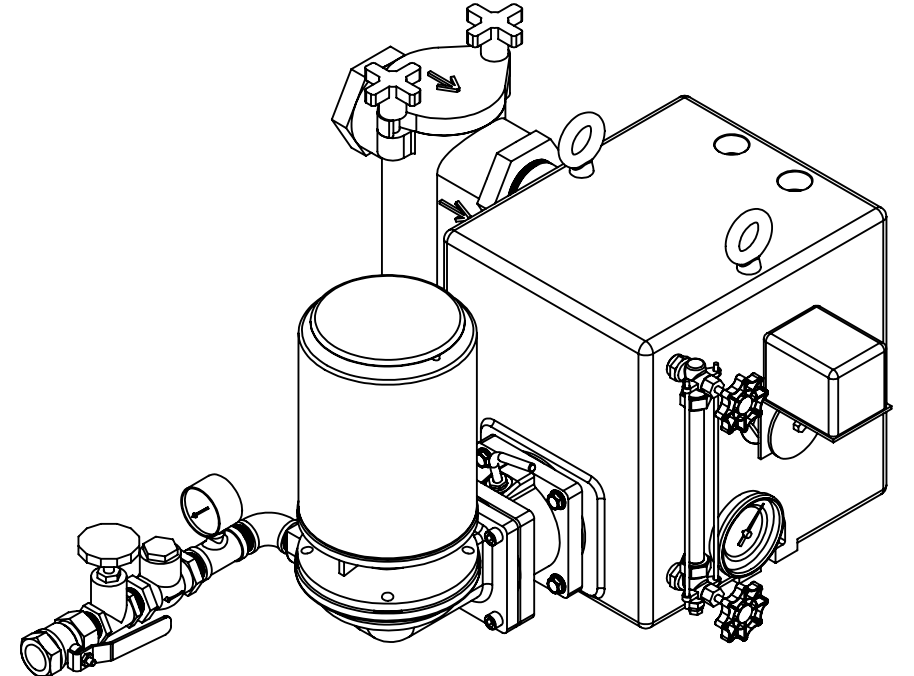
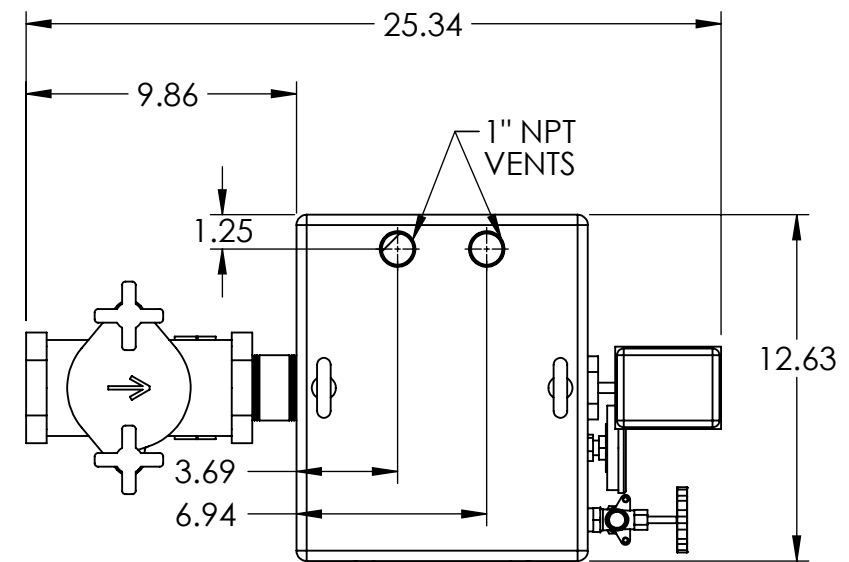

ISOLATION VALVE (OPTIONAL)

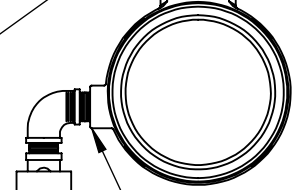

3/4" NPT PUMP DISCHARGE

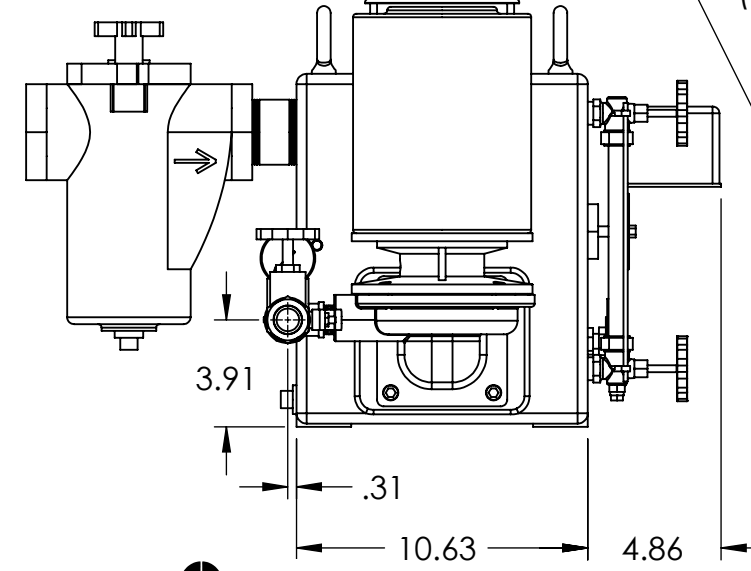
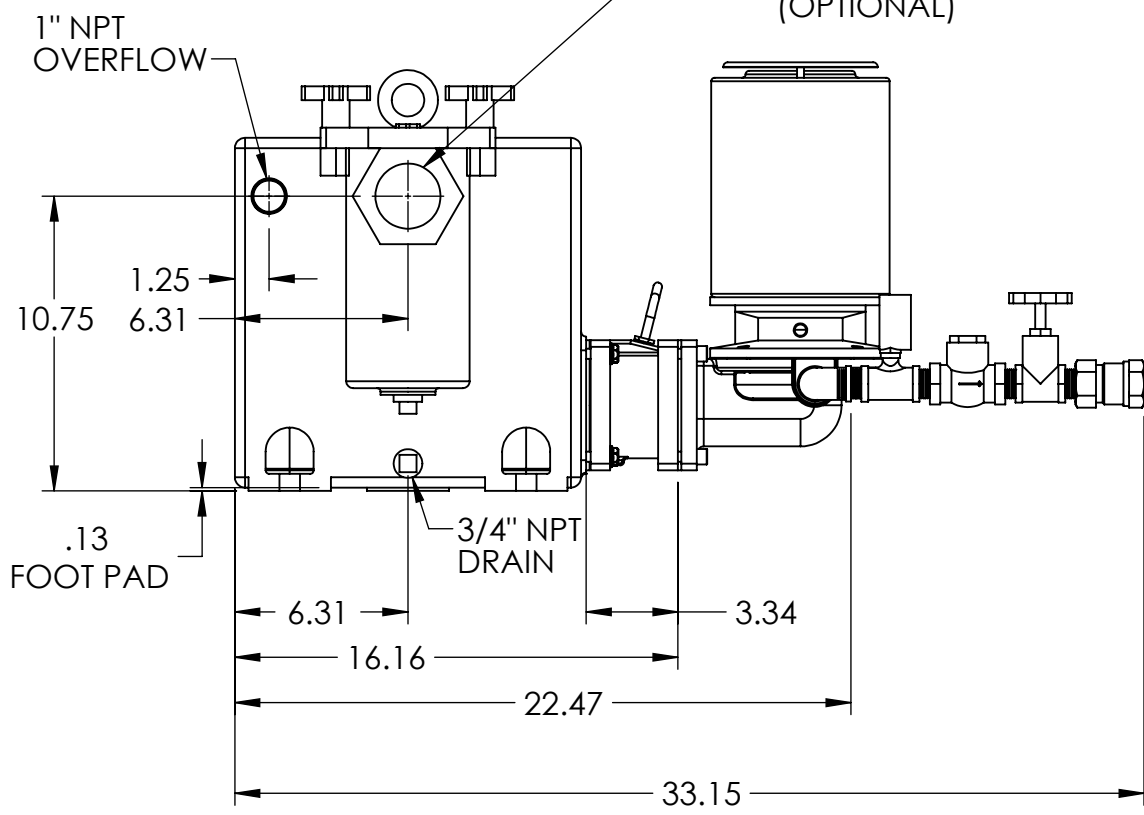

PRESSURE GAUGE, CHECK VALVE, GATE VALVE AND BALL VALVE (OPTIONAL)

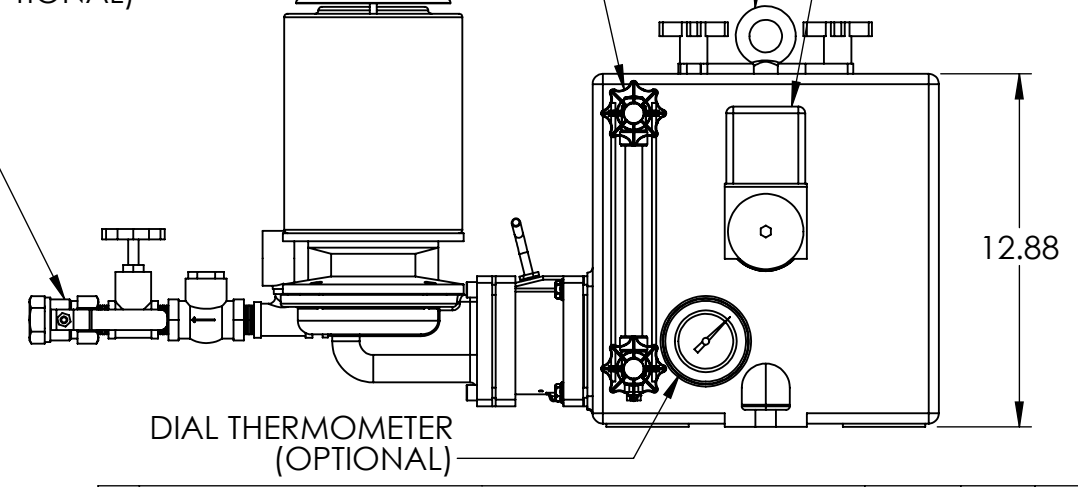

REV	DESCRIPTION	ECN	NAME	DATE
A	INITIAL DESIGN		GJM	12/5/2018
PART NO:	Ref PartNo	NAME	DATE	
FABRICATION TOLERANCES UNLESS OTHERWISE SPECIFIED: DIMENSIONS ARE IN INCHES		DRAWN	GJM	12/5/2018
TOLERANCES: ANGULAR DIMENSIONS ±1° FRACTIONS ±1/32		CHECKED		
TWO PLACE DECIMAL ±0.06 THREE PLACE DECIMAL ±0.030		ENG APPR.		
		PRODUCT FAMILY	HTSP Boiler and Condensate	
		PRODUCT CATEGORY	4200	
SHEET: 1 OF 1		WEIGHT	DRAWING MAY NOT BE PRINTED TO SCALE.	DWG NO.
			SCALE: 1:7	684.42006.00G
				REV
				A

**6 GALLON SIMPLEX
4200 SERIES
"G" CONDENSATE PUMP**