

NOTES:

- TANK MATERIAL: CAST IRON PER ASTM A48 CLASS 30
- ALL DIMENSIONS ARE ±0.25"
- DRAWING NOT FOR CONSTRUCTION
- CONSULT FACTORY AT TIME OF ORDER FOR CURRENT PRINT
- INLET BASKET STRAINER OR Y-STRAINER ALSO AVAILABLE

CONTROL PANEL OPTIONS ALSO AVAILABLE (NOT SHOWN):

- NEMA 4 OR NEMA 4X OR NEMA 3R CONSTRUCTION
- POWER ON LIGHT
- PUMP TEST BUTTON
- PUMP RUN TIME METER
- EXTRA DRY CONTACTS
- UL/CUL LABELED PANEL
- HIGH LEVEL ALARM HORN & LIGHT W/SILENCE SWITCH

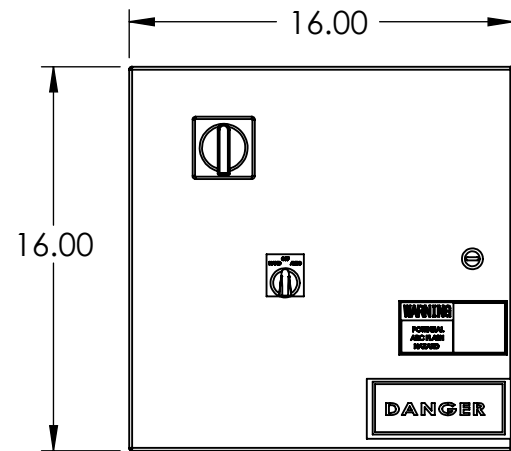

REMOTE MOUNTED
NEMA 12
CONTROL PANEL
(OPTIONAL)

PRESSURE GAUGE, CHECK VALVE,
GATE VALVE AND BALL VALVE
(OPTIONAL)

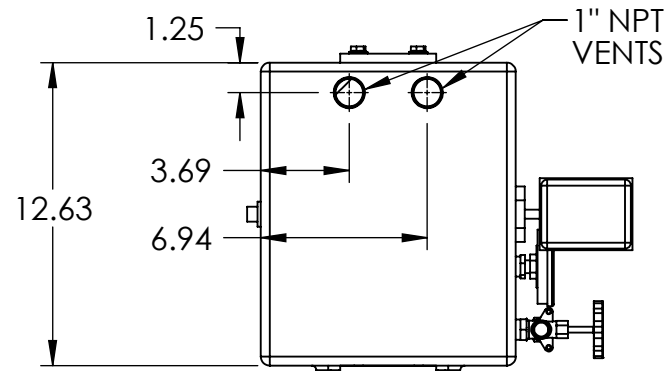

1" NPT
VENTS

1-1/2" NPT
PUMP
DISCHARGE

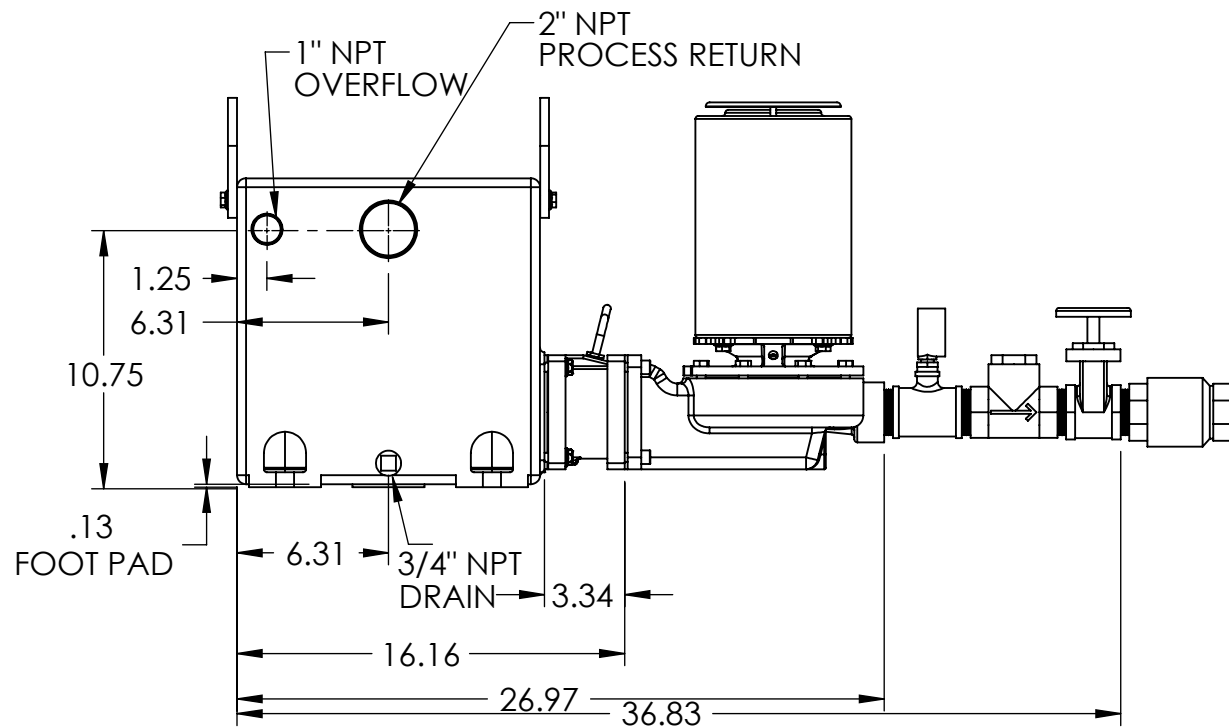
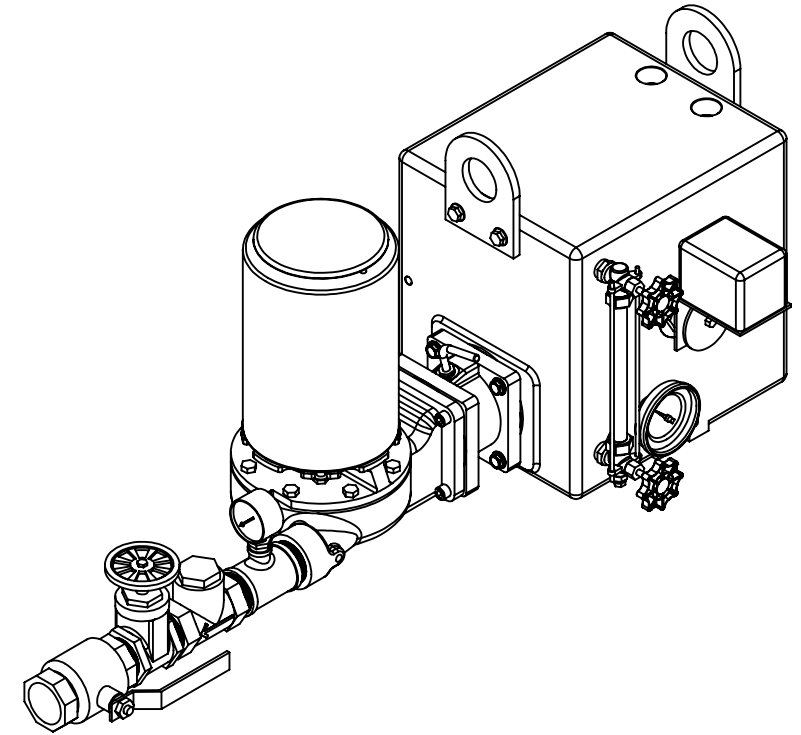

1" NPT
OVERFLOW

2" NPT
PROCESS RETURN

1.25

6.31

10.75

.13
FOOT PAD

6.31

3/4" NPT
DRAIN

3.34

16.16

26.97

36.83

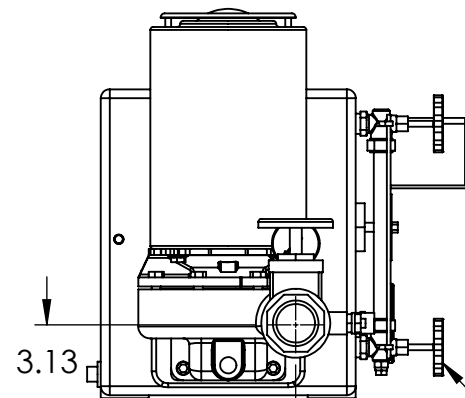

3.13

8.13

10.63

GAUGE GLASS
(OPTIONAL)

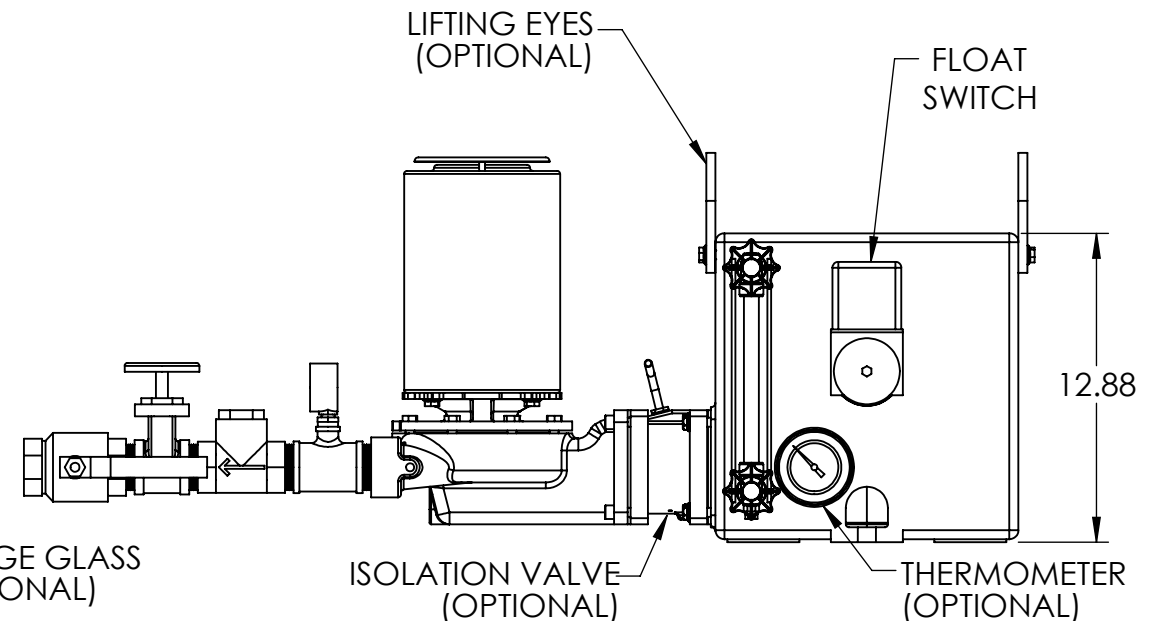

LIFTING EYES
(OPTIONAL)

FLOAT
SWITCH

12.88

ISOLATION VALVE
(OPTIONAL)

THERMOMETER
(OPTIONAL)



Armstrong
armstronginternational.com

REV	DESCRIPTION	ECN	NAME	DATE
B			GJM	5/10/2018

PART NO:	Ref PartNo	NAME	DATE	THIRD ANGLE PROJECTION
FABRICATION TOLERANCES UNLESS OTHERWISE SPECIFIED: DIMENSIONS ARE IN INCHES	DRAWN	GJM	2/19/2016	
TOLERANCES: ANGULAR DIMENSIONS ±1° FRACTIONS ±1/32	CHECKED			TITLE
TWO PLACE DECIMAL ±0.06 THREE PLACE DECIMAL ±0.030	ENG APPR.			6 GALLON SIMPLEX 4200 SERIES "J" CONDENSATE PUMP
	PRODUCT FAMILY	HTSP Boiler and Condensate		
	PRODUCT CATEGORY	4200		DWG NO.
SHEET: 1 OF 1	WEIGHT	DRAWING MAY NOT BE PRINTED TO SCALE.	SCALE: 1:7	684.42006.00J
				REV B