

# DIMENSIONS & DATA CERTIFIED FOR:

Representative:

Order:

Customer:

Order:

Project:

Requirements:

By:

Date:

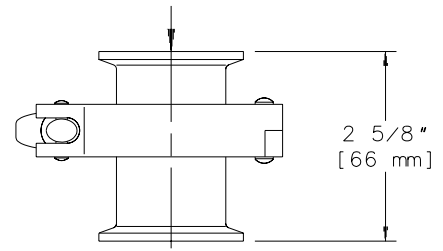
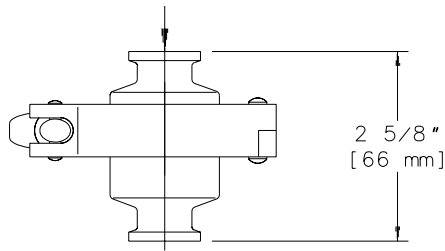
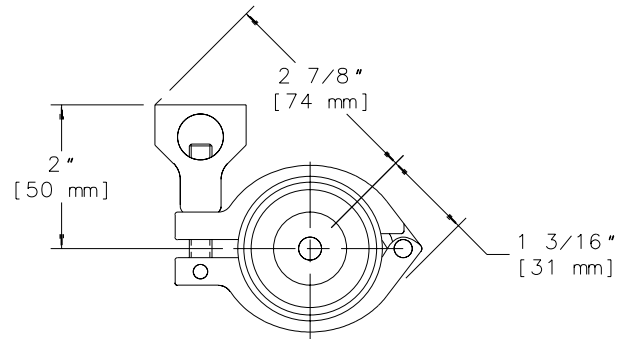
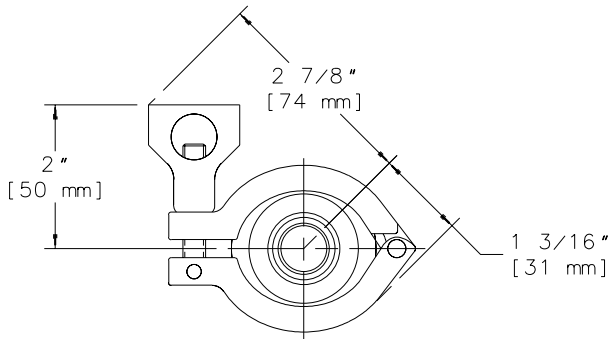

MODEL TC-C  
1/2 & 3/4  
SANITARY CONN.

MODEL TC-C  
1"  
SANITARY CONN.

2-FRONT

### LIST OF MATERIALS

NAME OF PART	MATERIAL
Cap	ASTM A479 316L Stn. Stl.
Body	ASTM A479 316L Stn. Stl.
Bellows	316L Stn. Stl.
Body Gasket	Viton
Retainer	316L Stn. Stl.
Clamp	Stn. Stl.

Pressure Maximum Allowable (PMA)-120 psig [8.3 bar]
Temperature Maximum Allowable (TMA)-350°F [177°C]
Pressure Maximum Operating [PMO]-100 psig [6.9 bar]
Finish: 180 Grit Electro Polish To 20 Ra or Below Inside, And 150 Grit Electro Polish To 30 Ra or Below On Outside
Weight: 1.25 lbs. [.57 kgs.]

3-RIGHT



Armstrong International, Inc.

Three Rivers Division

Three Rivers, MI 49093

Armstrong (616) 273-1415 Fax(616) 278-6555

Posted on Armstrong's homepage [www.armstrong-intl.com](http://www.armstrong-intl.com)

Product	CD No.	Date
CLEAN STEAM MODEL TC-C	1161	10/27/99
		Rev. A